



430-340-250 Left Side Discharge

Parts Manual

Revision 2023-08-17

Table Of Contents

Page	Content
1	SAFETY LABELS, FRONT
2	SAFETY LABELS, INSIDE OF DOOR/SHIELDS
3	SAFETY LABELS, DISCHARGE SIDE
4	SAFETY LABELS, REAR
5	SAFETY LABELS, NON-DISCHARGE SIDE
6	EXTERNAL FRONT ILLUSTRATION
7	EXTERNAL FRONT
8	PTO
9	PTO DRIVE LINE
10	SCALE SUPPORT ASSEMBLY
11	BOTTOM FRONT PTO DRIVE ASSEMBLY
12	FRONT SPEED REDUCTION & TUMBLER DRIVE ILLUSTRATION
13	FRONT SPEED REDUCTION & TUMBLER DRIVE
14	AUGER & ELEVATOR DRIVE ILLUSTRATION
15	AUGER & ELEVATOR DRIVE
16	ELEVATOR PARTS ILLUSTRATION
17	ELEVATOR PARTS
18	8 BOLT HUB ASSEMBLY FOR 250 & 340
19	COMPLETE HUB ASSEMBLIES FOR 250 & 340
20	10 BOLT HUB ASSEMBLY FOR 430
21	COMPLETE HUB ASSEMBLIES FOR 430
22	TUMBLER REAR DRIVE ILLUSTRATION
23	TUMBLER REAR DRIVE
24	EXTERNAL PARTS REAR
25	SPIRAL ASSEMBLY
26	KICKER
27	SWEEP KIT
28	POLY LINERS

**FARM AID LOGO
FA356**

LEFT HAND DISCHARGE IS ILLUSTRATED. A RIGHT HAND
DISCHARGED WOULD BE A MIRROR OF THIS IMAGE.

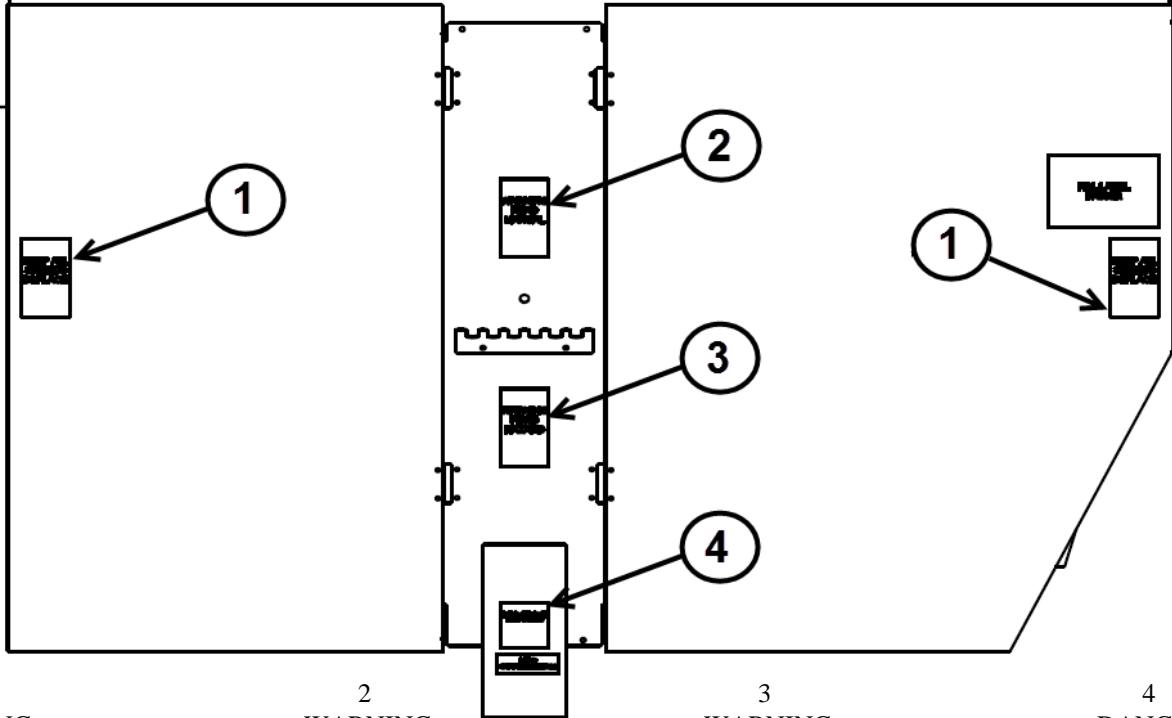

1
WARNING
SHIELDS

2
WARNING
READ MANUAL

3
WARNING
HIGH PRESSURE

4
DANGER
DRIVELINE

! WARNING

KEEP ALL SHIELD IN PLACE. KEEP HANDS AWAY FROM MOVING PARTS TO PREVENT SERIOUS INJURY OR DEATH.

! WARNING

TO PREVENT SERIOUS INJURY OR DEATH.

- READ AND UNDERSTAND OPERATOR'S MANUAL BEFORE USING. REVIEW ALL SAFETY PRECAUTIONS ANNUALLY.
- PLACE ALL CONTROLS IN NEUTRAL, STOP TRACTOR ENGINE, SET PARK BRAKE AND WAIT FOR ALL MOVING PARTS TO STOP BEFORE SERVICING, ADJUSTING, REPAIRING OR UNPLUGGING IMPLEMENT.
- DO NOT ALLOW RIDERS.
- SECURELY ATTACH TO TOWING UNIT USING A HARDENED PIN WITH A RETAINER AND AN AUXILIARY ATTACHING DEVICE.
- BE SURE ALL GUARD AND LOCKS ARE IN PLACE BEFORE STARTING.
- KEEP HANDS, FEET, HAIR AND CLOTHING AWAY FROM MOVING PARTS.
- BE SURE REFLECTORS AND SMV ARE VISIBLE BEFORE TRANSPORTING.
- DO NOT EXCEED A SAFE TRANSPORT SPEED.
- USE HAZARD FLASHERS ON TRACTOR WHEN TRANSPORTING.
- WHEN REPAIRING OR SERVICING IMPLEMENT, REFER TO OPERATOR'S MANUAL.

! WARNING

HIGH PRESSURE

FLUID HAZARD

TO PREVENT SERIOUS INJURY, OR DEATH.

- RELIEVE PRESSURE ON HYDRAULIC SYSTEM BEFORE SERVICING OR DISCONNECTING HOSES.
- WEAR PROPER HAND AND EYE PROTECTION WHEN SEARCHING FOR LEAKS.
- USE WOOD OR CARDBOARD INSTEAD OF HANDS.
- KEEP ALL COMPONENTS IN GOOD REPAIR.

! DANGER

ROTATING DRIVELINE HAZARD

TO PREVENT SERIOUS INJURY OR DEATH FROM ROTATING DRIVELINE.

- KEEP ALL GUARDS IN PLACE WHEN OPERATING.
- KEEP HANDS, FEET, HAIR, AND CLOTHING AWAY FROM MOVING PARTS.

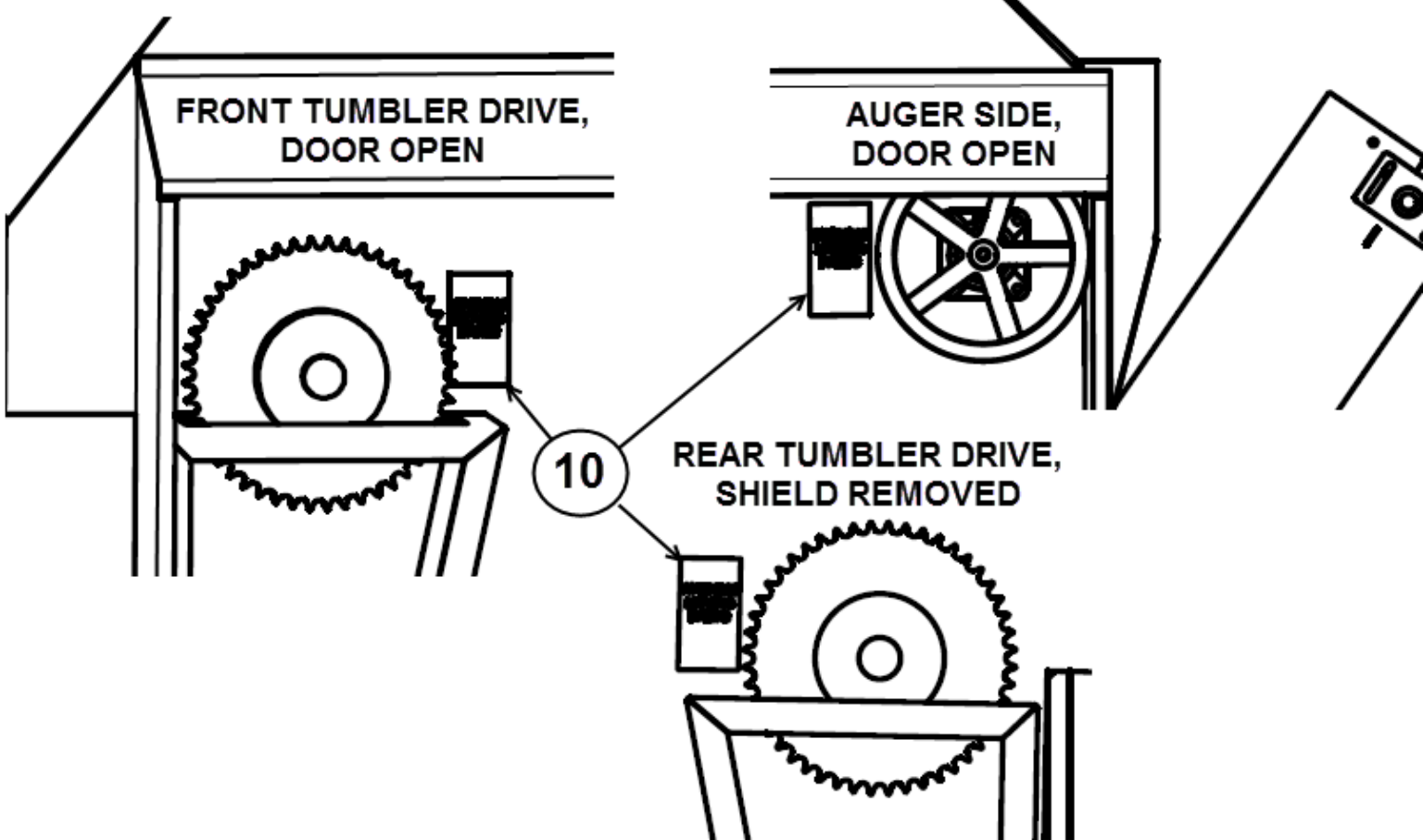

10
WARNING
MOVING PARTS

! WARNING

MOVING PART HAZARD

TO PREVENT SERIOUS INJURY, OR DEATH FROM MOVING PARTS:

- CLOSE AND SECURE GUARDS AND SHIELDS BEFORE STARTING.
- KEEP HANDS, FEET, HAIR, AND CLOTHING AWAY FROM MOVING PARTS.
- DISCONNECT AND LOCKOUT POWER SOURCE BEFORE ADJUSTING OR SERVICING.
- DO NOT STAND OR CLIMB ON MACHINE WHEN OPERATING.

LEFT HAND DISCHARGE IS ILLUSTRATED. A RIGHT HAND DISCHARGE WOULD BE A MIRROR OF THIS IMAGE.

LEFT HAND DISCHARGE IS ILLUSTRATED. A RIGHT HAND DISCHARGED WOULD BE A MIRROR OF THIS IMAGE.

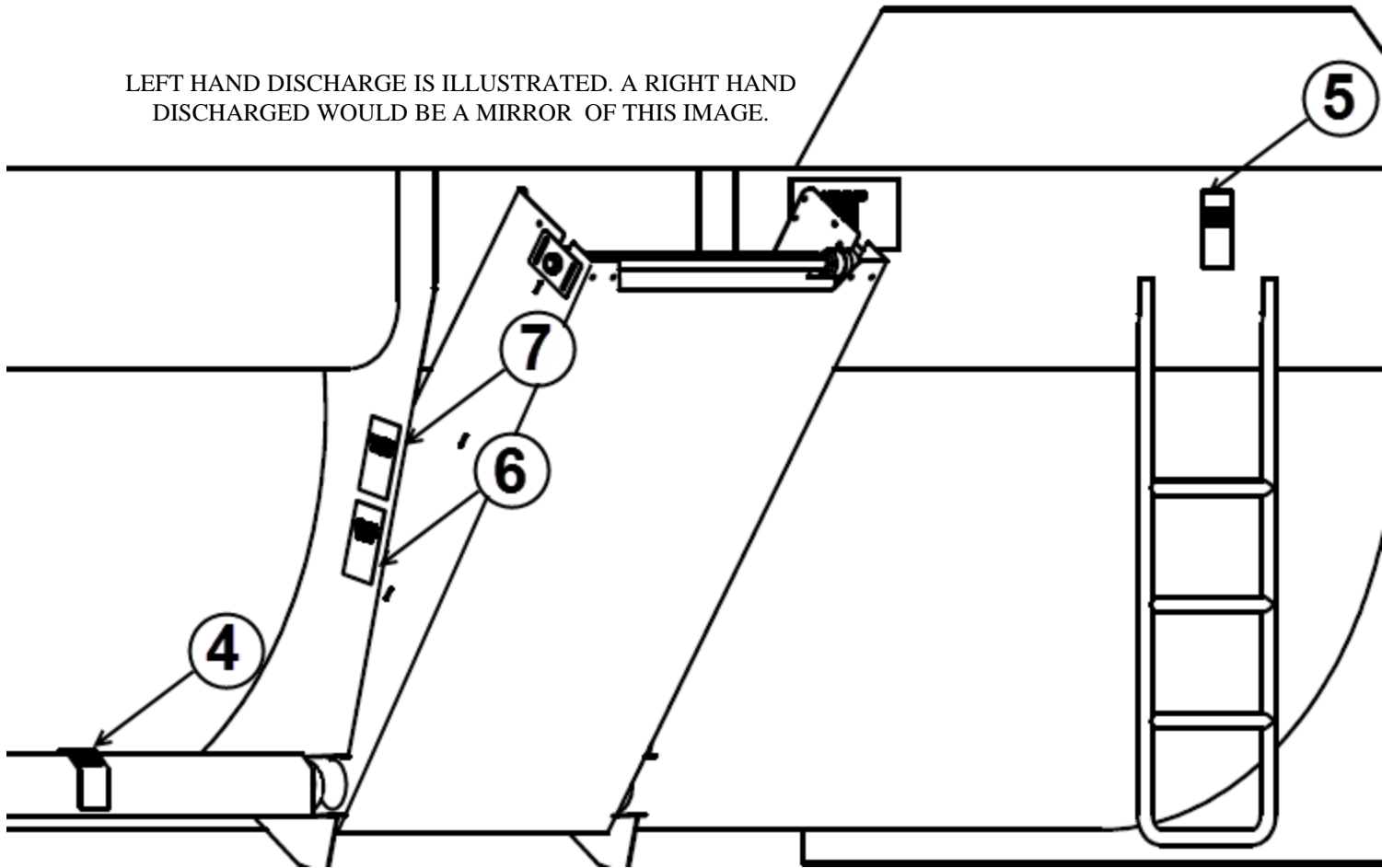

4
DANGER
DRIVELINE

5
DANGER
AUGER

6
WARNING
CRUSHING

7
DANGER
CHUTE

⚠ DANGER

ROTATING DRIVELINE HAZARD

TO PREVENT SERIOUS INJURY OR DEATH FROM ROTATING DRIVELINE.

- KEEP ALL GUARDS IN PLACE WHEN OPERATING.
- KEEP HANDS, FEET, HAIR, AND CLOTHING AWAY FROM MOVING PARTS.

⚠ DANGER

NO ENTRY

AUGER ENTANGLEMENT HAZARD

TO PREVENT SERIOUS INJURY OR DEATH FROM ROTATING PARTS.

- DO NOT ENTER MIXING CHAMBER WHEN TRACTOR IS RUNNING OR WHEN AUGER IS IN MOTION.
- KEEP HANDS AND FEET AWAY FROM MIXING CHAMBER.

⚠ WARNING

CRUSHING OF HAND OR FINGERS

TO PREVENT SERIOUS INJURY, STAY CLEAR OF MOVING PARTS.

⚠ DANGER

STAY CLEAR OF CHUTE AREA!

CHUTE POSITION AND DISCHARGE CHAIN ARE REMOTELY CONTROLLED AND CAN OPERATE WITHOUT MIXER RUNNING. CHUTE RAISES AND LOWERS RAPIDLY, AND CHAIN STARTS WHEN CHUTE LOWERS.

**FARM AID LOGO
FA356**

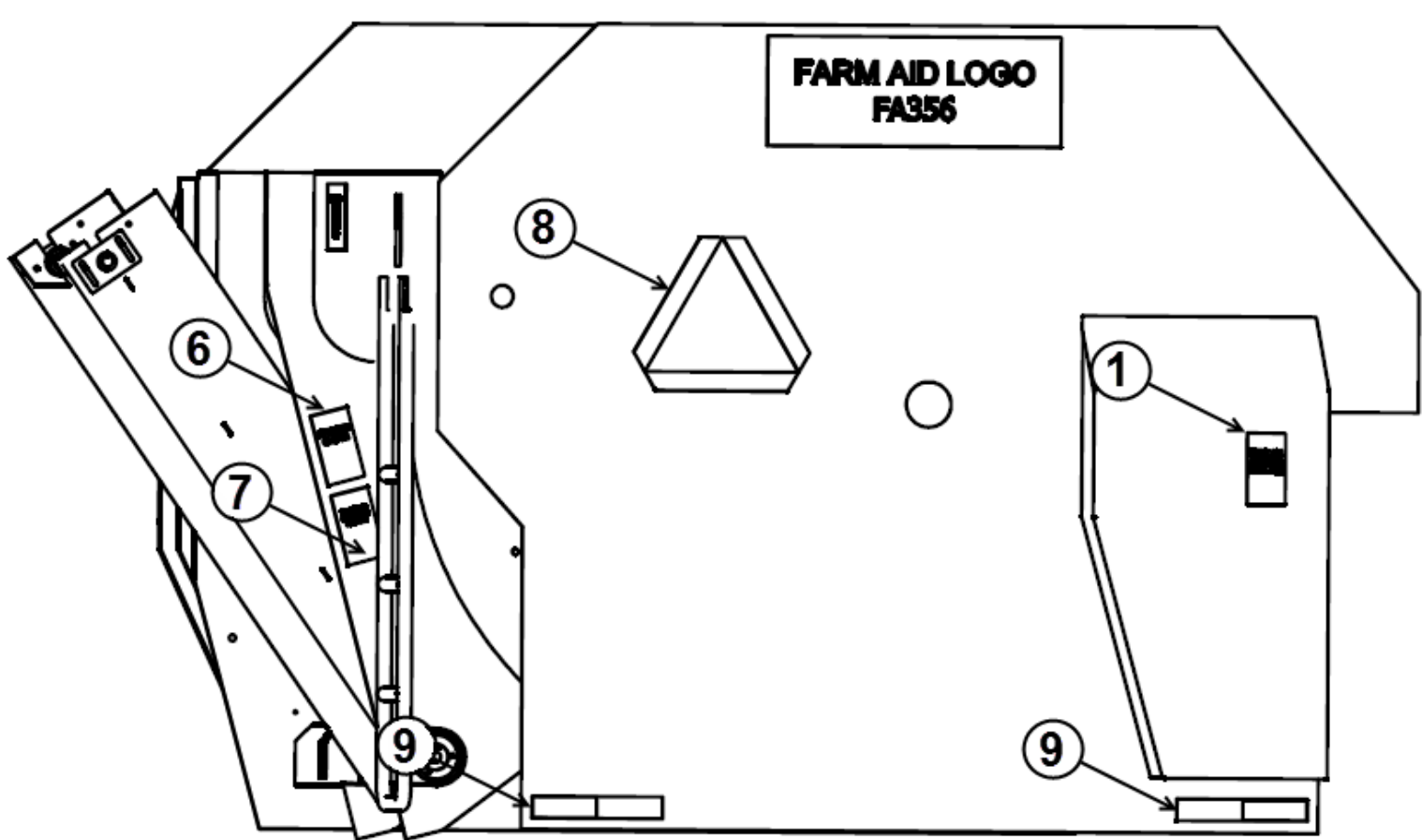

LEFT HAND DISCHARGE IS ILLUSTRATED. A RIGHT HAND DISCHARGE WOULD BE A MIRROR OF THIS IMAGE.

1
WARNING
SHIELDS

6
WARNING
CRUSHING

7
DANGER
CHUTE

8
SLOW MOVING
VEHICLE LABEL
P/N FA357

9
REFLECTIVE LABEL
P/N FA359

! WARNING

KEEP ALL SHIELD IN PLACE. KEEP HANDS AWAY FROM MOVING PARTS TO PREVENT SERIOUS INJURY OR DEATH.

! WARNING

CRUSHING OF HAND OR FINGERS

TO PREVENT SERIOUS INJURY, STAY CLEAR OF MOVING PARTS.

! DANGER

STAY CLEAR OF CHUTE AREA!

CHUTE POSITION AND DISCHARGE CHAIN ARE REMOTELY CONTROLLED AND CAN OPERATE WITHOUT MIXER RUNNING. CHUTE RAISES AND LOWERS RAPIDLY, AND CHAIN STARTS WHEN CHUTE LOWERS.

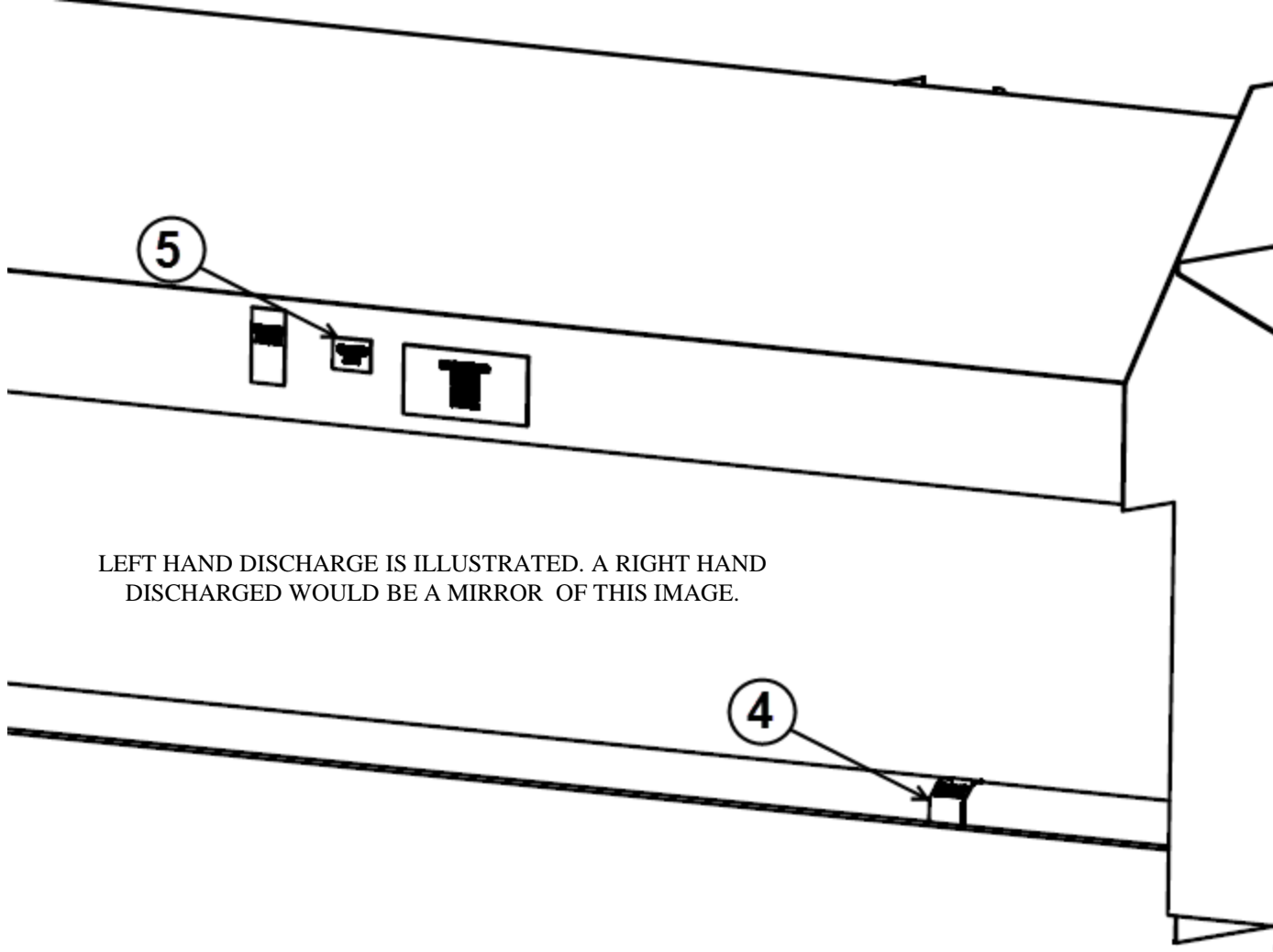

LEFT HAND DISCHARGE IS ILLUSTRATED. A RIGHT HAND DISCHARGE WOULD BE A MIRROR OF THIS IMAGE.

4
DANGER
DRIVELINE

5
DANGER
AUGER

! DANGER

ROTATING DRIVELINE HAZARD

TO PREVENT SERIOUS INJURY OR DEATH FROM ROTATING DRIVELINE.

- KEEP ALL GUARDS IN PLACE WHEN OPERATING.
- KEEP HANDS, FEET, HAIR, AND CLOTHING AWAY FROM MOVING PARTS.

! DANGER

NO ENTRY

AUGER ENTANGLEMENT HAZARD

TO PREVENT SERIOUS INJURY OR DEATH FROM ROTATING PARTS.

- DO NOT ENTER MIXING CHAMBER WHEN TRACTOR IS RUNNING OR WHEN AUGER IS IN MOTION.
- KEEP HANDS AND FEET AWAY FROM MIXING CHAMBER.

LEFT

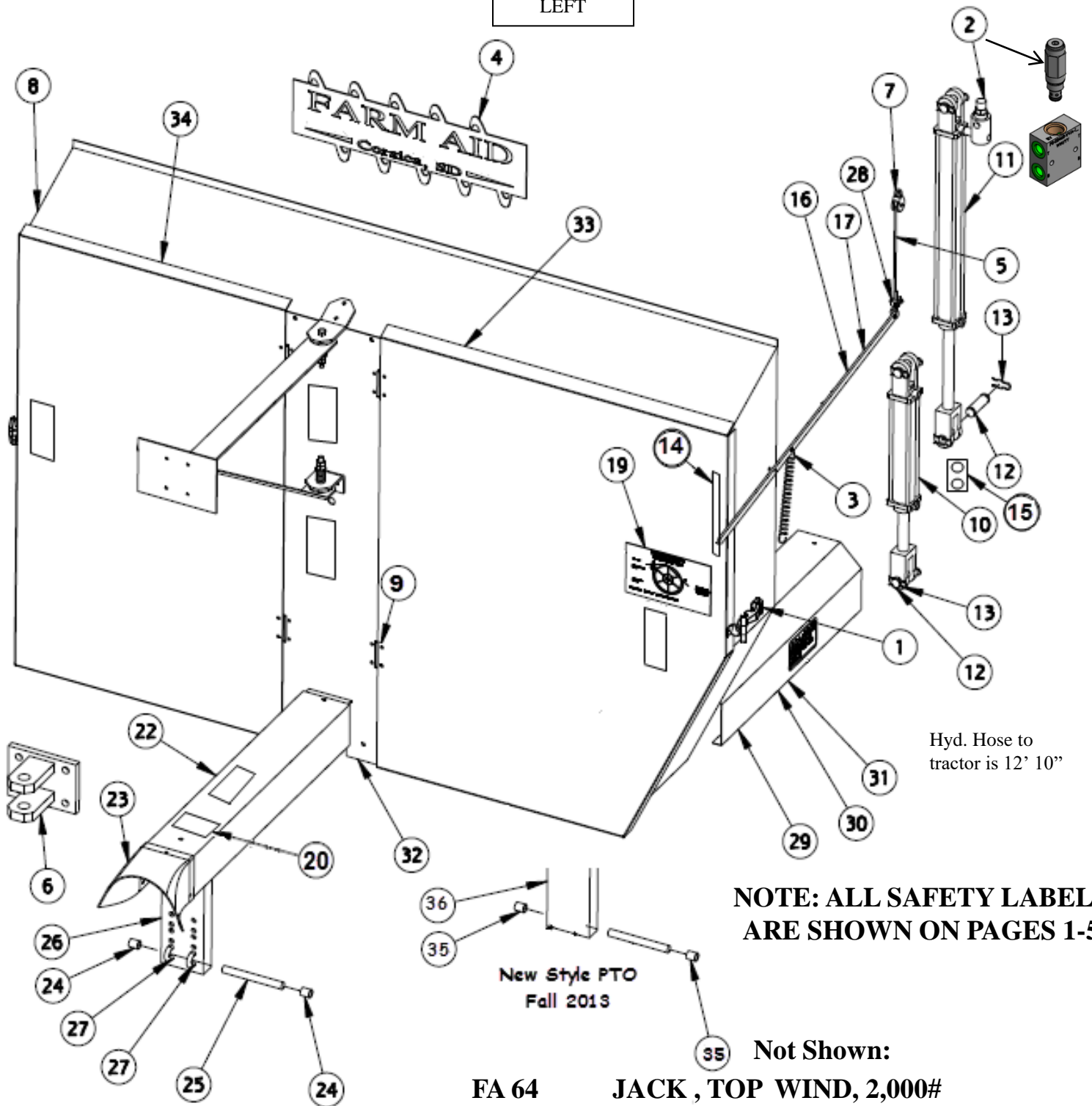

Hyd. Hose to tractor is 12' 10"

NOTE: ALL SAFETY LABELS ARE SHOWN ON PAGES 1-5

Not Shown:

- FA 64 JACK , TOP WIND, 2,000#**
- FA 64A JACK , SIDE WIND, 2,000#**
- FAC604S JACK, SIDE WIND, 4,000# TALL**
- FA753 BUNK GUARD FOR 430**
- FA752 BUNK GUARD FOR 340**
- FA356K DECAL KIT**
- FA175 Hyd. Hose Bracket**

ITEM	P/N	DESCRIPTION
1	FA 001	SHIED TIE, COMPLETE (FA002 - RUBBER TIE ONLY)
2	FA020-ROUND	BYPASS VALVE WITH A STEEL CYLINDRICAL BODY
2	FA020-VALVE	BYPASS VALVE ONLY FOR VALVES WITH AN ALUMINUM RECTANGULAR BODY
3	FA 277	SPRING, DOOR INDICATOR
4	FA 356	DECAL, FARM AID EQUIPMENT
5	FA 541	CABLE, INDICATOR BAR; 17.5" TO IDLER; 27.5" RELAY TO ELEVATOR; 50" TO INDICATOR
6	FA 604	HITCH ; WEAR PLATE ONLY IS FA 603; HITCH WITH MOUNTING PLATE IS FA604CU
7	FA 800	PULLEY, INDICATOR BAR
8	FA 810	TOP SHIELD, MODELS 250, 340, & 430 SPECIFY RIGHT OR LEFT DISCHARGE
9	FA810H	HINGE 250/340/430
10	FA 20-10	HYD CYLINDER, 2.00 BORE X 10.0 STROKE
11	FA 20-24	HYD CYLINDER, 2.00 BORE X 24.0 STROKE
	FA 639572	CYLINDER SEAL KIT, ALL FARM AID CYLINDERS
12	FA 352P	CYLINDER PIN
13	FA 352PC	RETAINER, CYLINDER PIN
14	FA 354	DOOR INDICATOR BAR DECAL
15	FA 520	CYLINDER CONNECTOR
16	FA 353-34	DOOR INDICATOR BAR, MODEL 340
17	FA 353-43	DOOR INDICATOR BAR, MODEL 430
19	FA 355R	DECAL, FILL LEVEL
20	L-PTO OPP.	DECAL, PTO OPERATION
22	FA 410S	GUARD, PTO
23	FA 411B	RUBBER GUARD, PTO
24	FA 412B	BUSHING, HINGED PTO
25	FA 412P	PIVOT SHAFT, HINGED PTO
26	FA 412SH	HINGED PTO STAND, MODELS 250, 340, & 430
27	FA 412U	U-BOLT, HINGED MOUNT
28	FA 541C	CABLE CLAMP
29	FA 580-2	GUARD, ELEVATOR DRIVE, MODEL 250 SPECIFY RIGHT OR LEFT DISCHARGE
30	FA 580-3	GUARD, ELEVATOR DRIVE, MODEL 340 SPECIFY RIGHT OR LEFT DISCHARGE
31	FA 580-4	GUARD, ELEVATOR DRIVE, MODEL 430 SPECIFY RIGHT OR LEFT DISCHARGE
32	FA 810C	DOOR MOUNT PANEL
33	FA 810L	DOOR, ANGLE, SPECIFY RIGHT OR LEFT DISCHARGE
34	FA 810R	DOOR, SQUARE, SPECIFY RIGHT OR LEFT DISCHARGE
35	FA 409B	5/8" BUSHING
36	FA 409	1 PC HINGED PTO STAND

LEFT

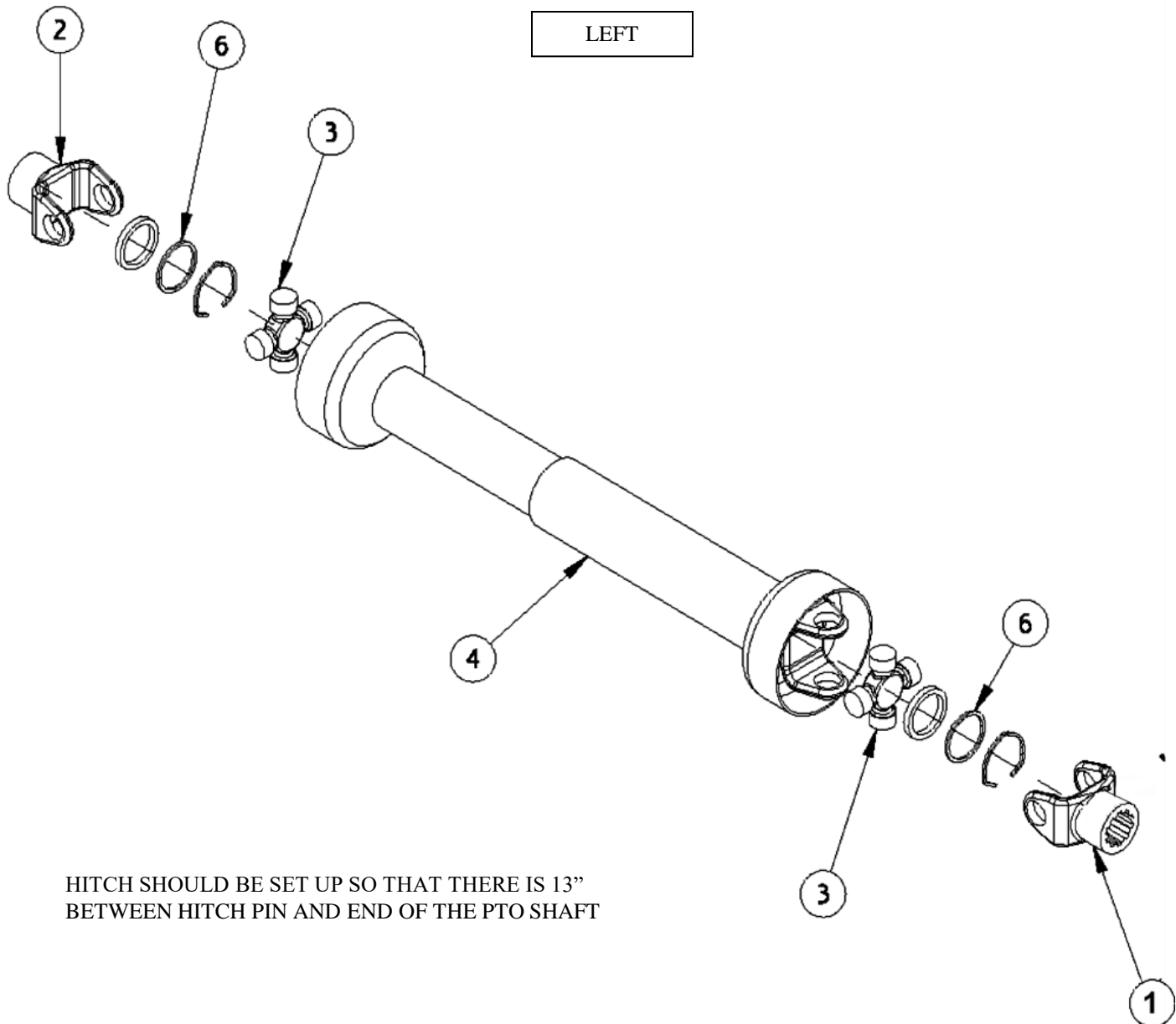

HITCH SHOULD BE SET UP SO THAT THERE IS 13" BETWEEN HITCH PIN AND END OF THE PTO SHAFT

ITEM	P / N	DESCRIPTION
1	FA 413	6 SPLINE, 1-3/8 SNAP BALL TYPE YOKE
1	FA 413-21 (1000 RPM)	21 SPLINE, 1-3/8 SNAP BALL TYPE YOKE
1	FA 413G	6 SPLINE 1-3/8 PIN TYPE YOKE
1	FA 417W	REPAIR KIT FOR SNAP BALL YOKE
1	FA 417G	REPAIR KIT FOR PIN TYPE YOKE
2	FA 414	1-1/4 ROUND YOKE, 12 SERIES
3	FA 415	CROSS & BEARING KIT, 12 SERIES
4	FA 416W	BLACK PLASTIC PTO SHIELD
4	FA 416G	ORANGE PLASTIC PTO SHIELD
6	FA 416BK	SHIELD BEARING KIT

8	PTO	8
---	-----	---

540 RPM	DESCRIPTION	1000 RPM
FA 310	PULLEY 7"	FA 307
FA 312	PULLEY 14"	FA308
FA 202A	SPROCKET	FA 201M
FA 205B	BUSHING	FA 201B
FA 205A	SPROCKET	FA 205A-10
FA 413	YOKE	FA 413-21
-----	IDLER ADAPTER	FA 330CA
THE 1000 RPM REQUIRES 3" ADDITIONAL CHAIN		

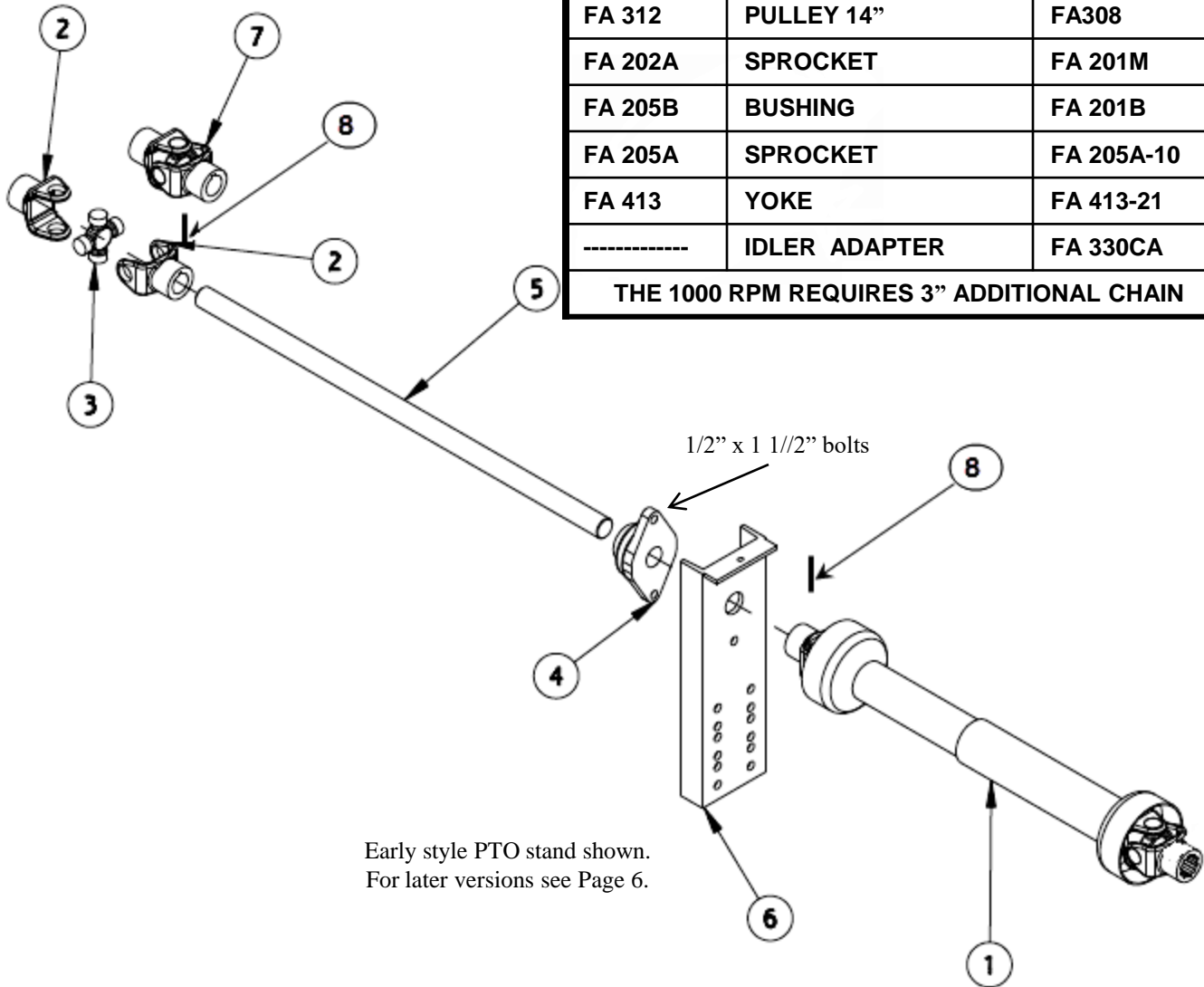

Early style PTO stand shown.
For later versions see Page 6.

ITEM	P / N	DESCRIPTION
1	FA 412	COMPLETE PTO, 12 SERIES X 28"
1	FA412-21	COMPLETE PTO, 12 SERIES X 28" W / 21 SLINE (1000 RPM)
2	FA 414	1-1/4 ROUND YOKE, 12 SERIES
3	FA 415	CROSS & BEARING KIT, 12 SERIES
4	FA 101FB-2	FLANGE BEARING, 2-BOLT, 1-1/4 BORE W/LOCKING COLLAR
5	FA 401E	1-1/4 X 31-3/4 PTO EXTENSION SHAFT
6	FA 409	1 PC HINGED PTO STAND (LATE 2013 NOT SHOWN)
6	FA 412SH	U-BOLT HINGED PTO STAND (SHOWN)
7	FA 414D	COMPLETE DOUBLE YOKE
8	FA412RP	ROLL PIN 1/4" x 2"
	FA 412KEY	1/4" X 1 1/4" KEY

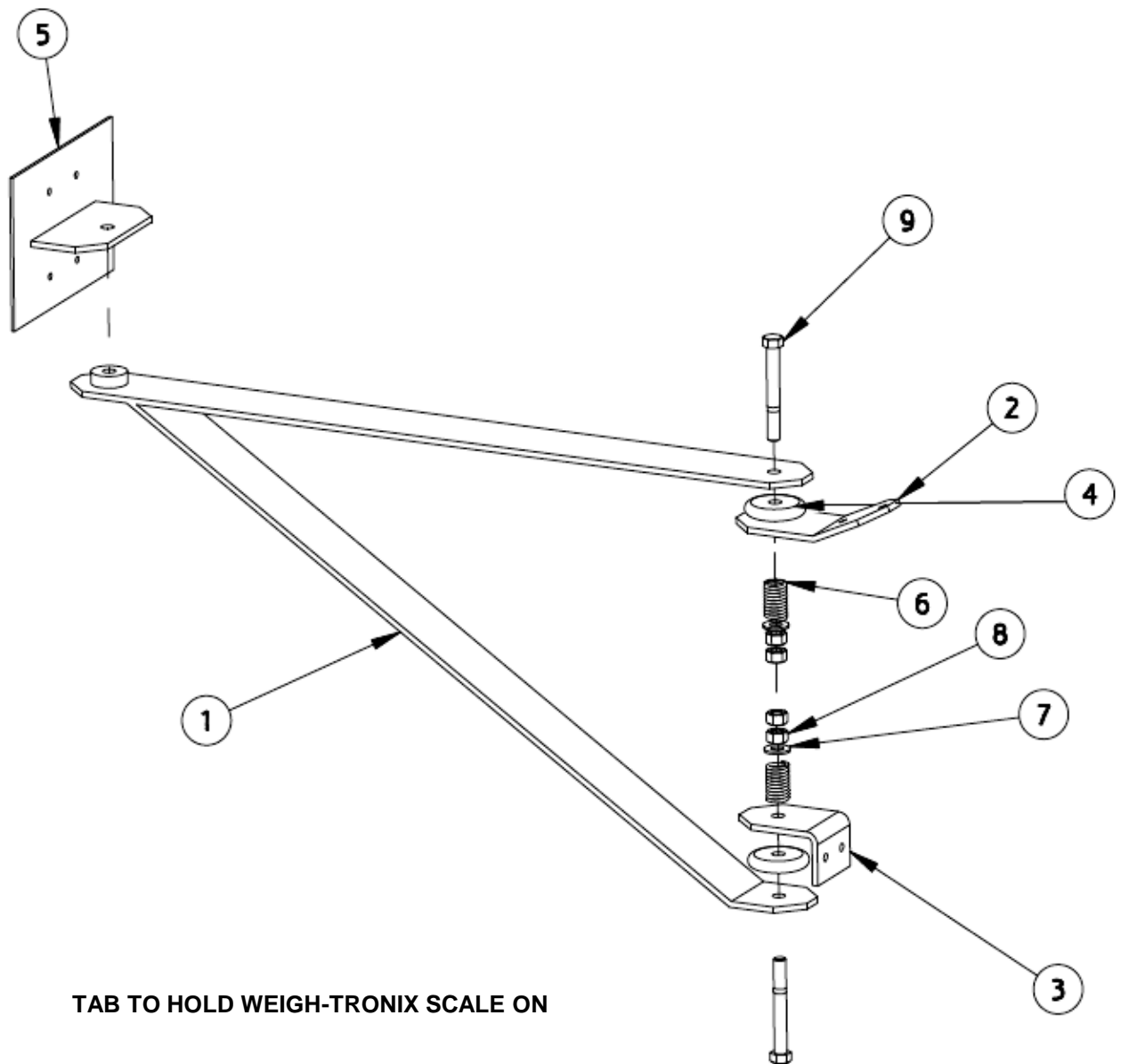

FA130 TAB TO HOLD WEIGH-TRONIX SCALE ON

ITEM	PART NUMBER	DESCRIPTION
1	FA-130 SIB	SCALE SUPPORT
2	FA-133	SUPPORT BRACKET, UPPER
3	FA-134	SUPPORT BRACKET, LOWER
4	FA-135	SHOCK ABSORBER
5	FA-130B	SCALE MOUNT BRACKET
6	FA-131S	COMPRESSION SPRING
7		FLAT WASHER, 1/2 TYPE A
8		HEX NUT, 1/2
9		HEX HD SCREW, 1/2 X 3 1/2

LEFT

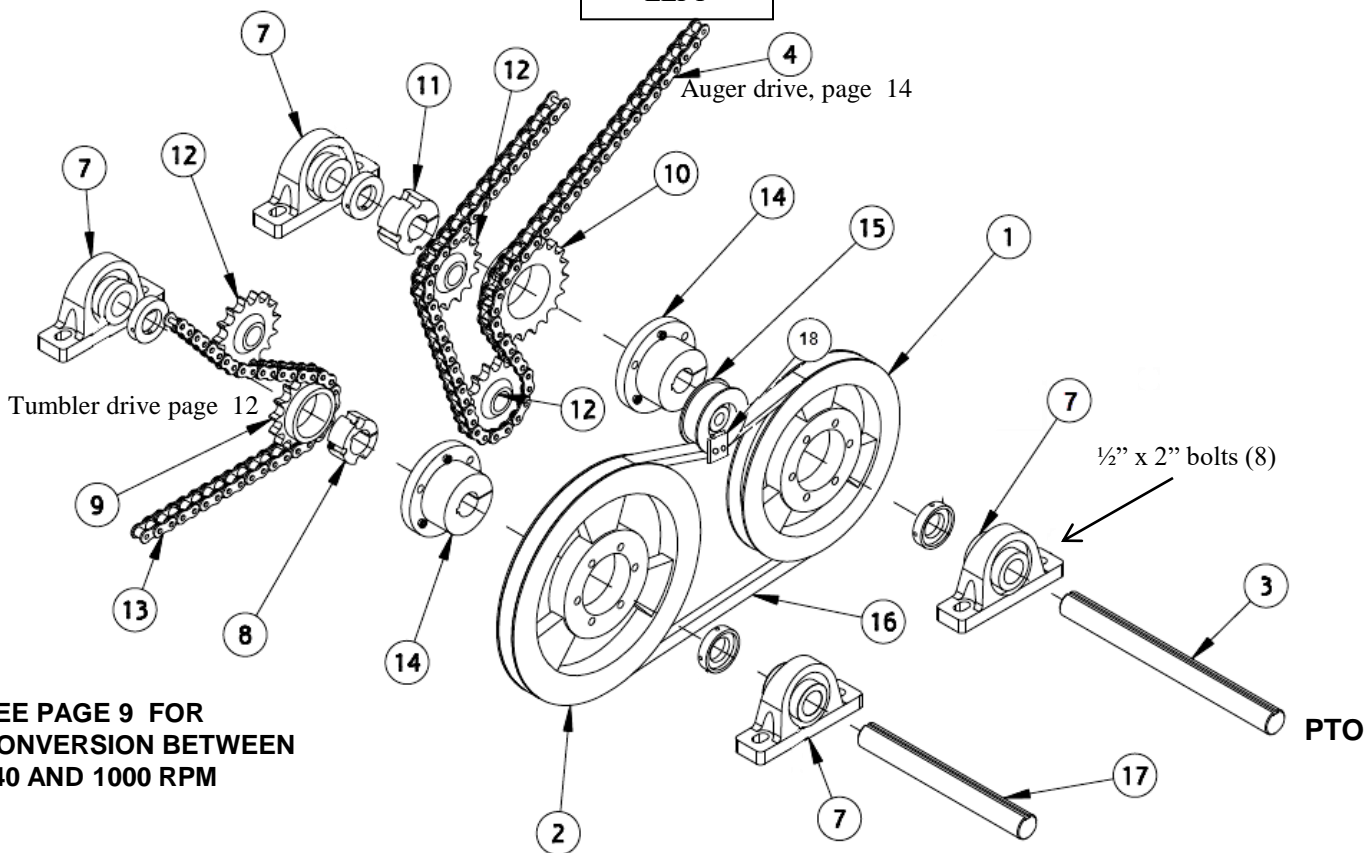

SEE PAGE 9 FOR
CONVERSION BETWEEN
540 AND 1000 RPM

ITEM	P / N	DECSRIPTION
-----	FA1320	ELECTRIC MOTOR TO MIXER DRIVE BELT
1	FA 310 (540 RPM)	1C 10" PULLEY
1	FA 307 (1000 RPM)	1C 7" PULLEY
2	FA 312 (540 RPM)	1C 12" PULLEY
2	FA 308 (1000 RPM)	1C 14" PULLEY
3	FA 401	PTO SHAFT, 1-1/4" X 13-1/2"
4	FA 313L	60 CHAIN, 95-1/4" (128 ROLLERS)
7	FA 101PB	PILLOW BLOCK BEARING, 1-1/4"
8	FA 201B	1610 TAPER LOCK BUSHING, 1-1/4"
9	FA 201M	6015 SPROCKET, 15T-60, TAPER LOCK
10	FA 202A	6020 SPROCKET, 20T-60, TAPER LOCK
10	FA 201M (1000 RPM)	6015 SPROCKET, 15T-60, TAPER LOCK
11	FA 205B	2012 TAPER LOCK BUSHING, 1-1/4"
11	FA 201B (1000 RPM)	1610 TAPER LOCK BUSHING, 1-1/4"
12	FA 210M	6015 IDLER SPROCKET, 15T-60
13	FA 214-60L	59-1/4" 60 CHAIN W/CONNECTOR (80 ROLLERS)
14	FA 312B	OD-SF BUSHING, 1-1/4"
15	FA 330C	SINGLE IDLER PULLEY, C BELT
16	FA 360M	CX 60 BELT, MIXER DRIVE
17	FA 402A	SHAFT, 1-1/4" X 10-1/2"
18	FA 330CA (1000 RPM)	IDLER PULLEY ADAPTER

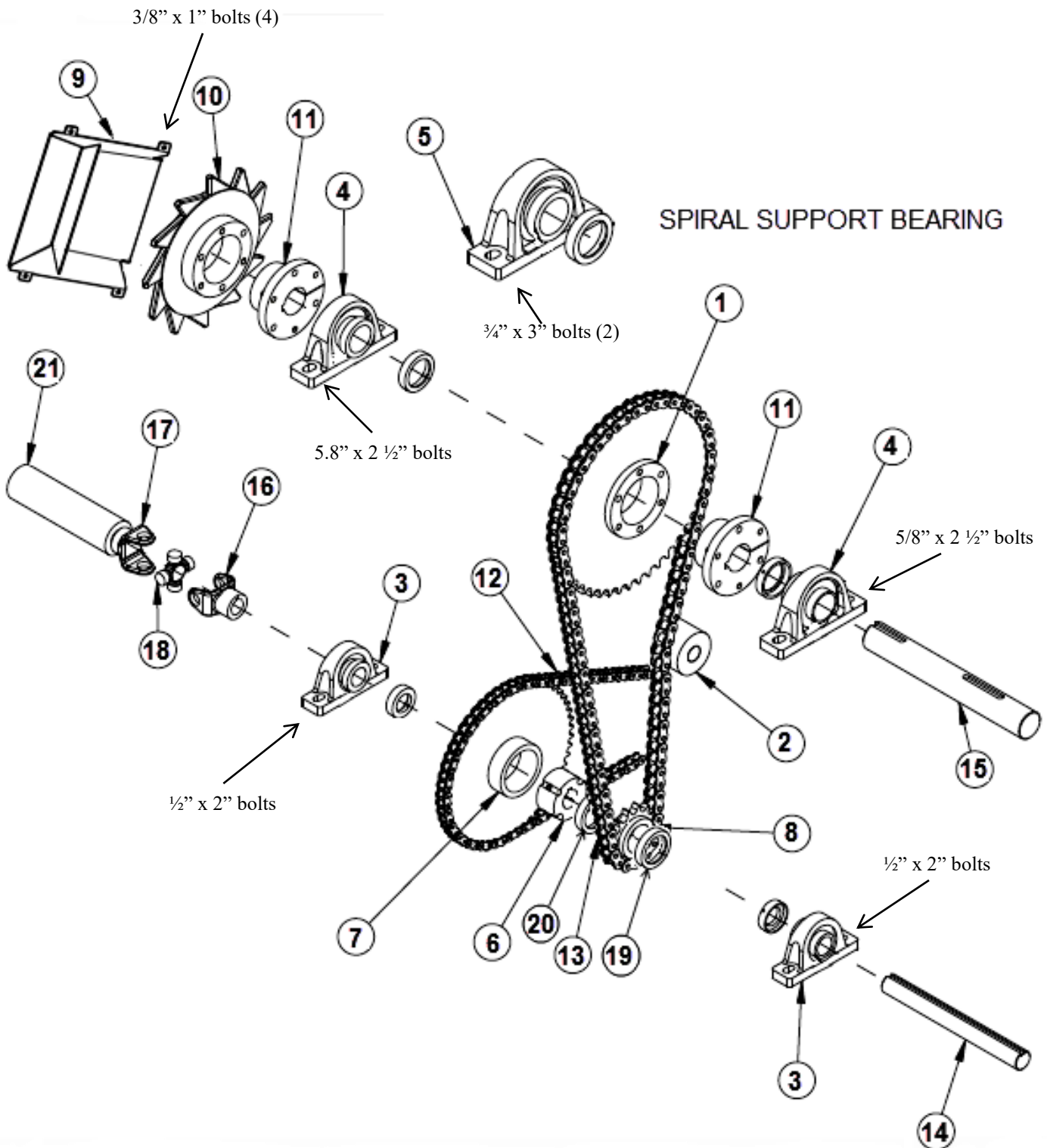

ITEM	P / N	DESCRIPTION
1	FA 208	8048 SPROCKET FOR USE WITH A QD SIZE E BUSHING. DURING 2013 AND 2014 SOME MIXERS WERE BUILT WITH A SPROCKET THAT USED A TAPERLOCK BUSHING. SPROCKET FAC245 AND BUSHING FAC245H. THESE ARE DISCONTINUED.
2	FA 340	PLASTIC IDLER
3	FA 102PB	PILLOW BLOCK BEARING, 1-1/2"
4	FA 103PB	PILLOW BLOCK BEARING, 2-3/16"
5	FA 104PB	PILLOW BLOCK BEARING, 2-15/16"
6	FA 206H	2517 TAPER LOCK BUSHING, 1-1/2"
7	FA 206S	60BT54 SPROCKET, TAPER LOCK
8	FA 207S	80B11 SPROCKET, THIS COMES AS A KIT AND INCLUDES ONE FA207LC (19) AND ONE FA207B (21)
9	FA 212-SQR	SQUARE SPIDER SHIELD EARLIER MACHINES USED A TEAR DROP SHAPED SHIELD THAT IS OBSOLETE. MOUNTING THIS PART WILL REQUIRE DRILLING 4 HOLES TO INSTALL.
10	FA 212	SPIDER, (IT IS RECOMMENDED TO REPLACE THE MOUNTING BOLTS)
	FA 212BLT	BOLT FOR SPIDER GEAR AND 8048 SPROCKET
11	FA 208B	QD E BUSHING, 2-3/16"
12	FA 214-60L	59-1/4" 60 CHAIN (80 ROLLERS)
13	FA 214-80	81" 80 CHAIN, (82 ROLLERS)
14	FA 403FS	SHAFT, 1-1/2" X 13"
15	FA 404FS	SHAFT, 2-3/16" X 14"
16	FA 406S	14 SERIES, 1-1/2" YOKE
17	FA 407S	14 SERIES, YOKE TUBE WELD
18	FA 408S	14 SERIES CROSS & BEARING KIT
19	FA 207LC	LOCKING COLLAR.
20	FA 207B	BUSHING 1-1/2" X 7/16" SPACER BETWEEN SPROCKETS
21	FA 406CU	COMPLETE DRIVE SHAFT WITH BOTH YOKES

SEE PAGE 9 FOR
CONVERSION BETWEEN
540 AND 1000 RPM

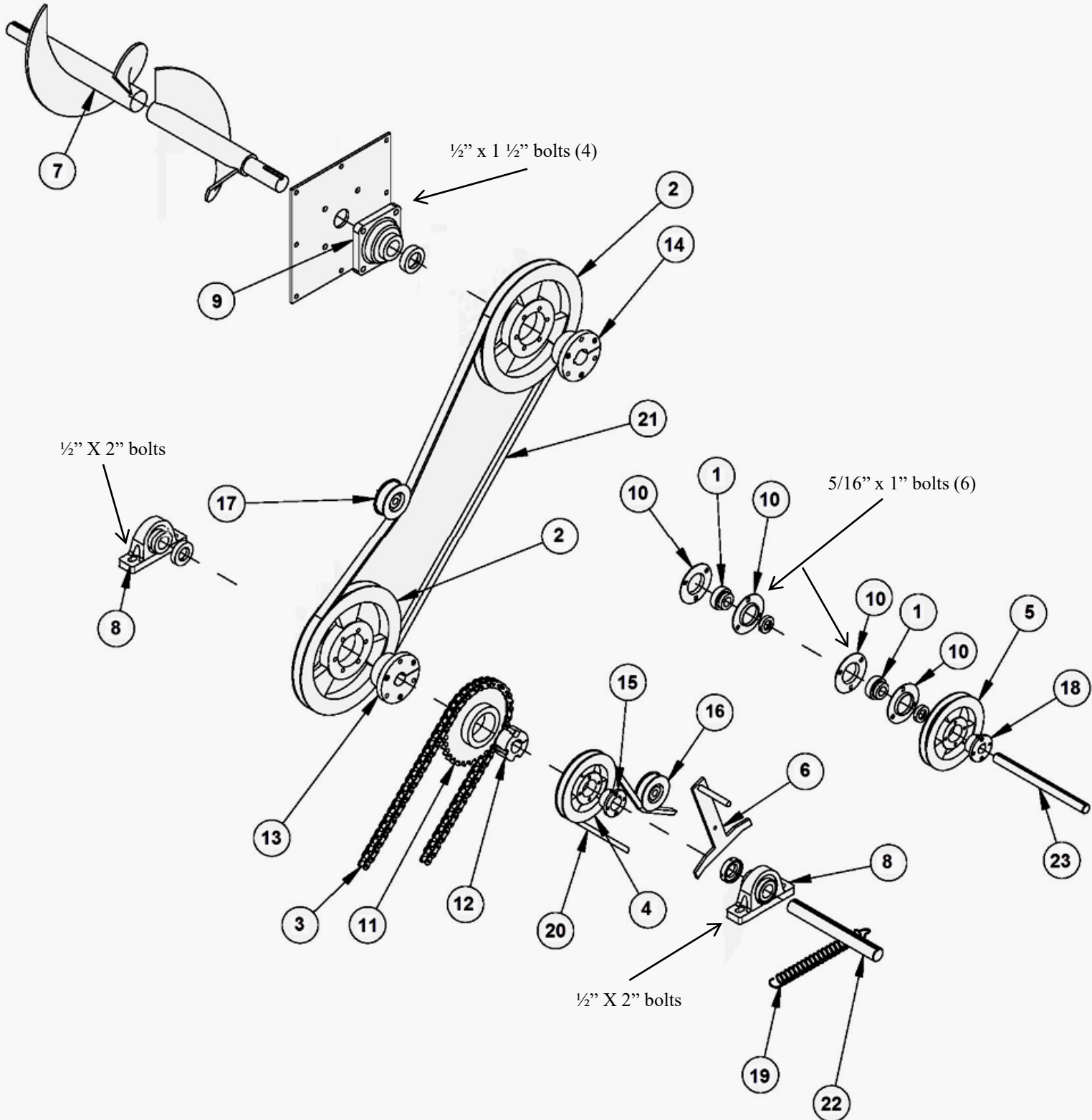

LEFT

ITEM	P / N	DESCRIPTION
1	FA 107	7/8" BEARING
2	FA 312	1C 12.0 PULLEY
3	FA 313L	60 CHAIN, 95-1/4" (128 ROLLERS)
4	FA 326	1 GROOVE B BELT PULLEY, 6-1/2"
5	FA 327	1 GROOVE B BELT PULLEY, 7"
6	FA 331	TIGHTENER ARM ASSEMBLY
7	FA 709 L/R	AUGER FOR MODEL 250, LEFT OR RIGHT HAND
7	FA 712 L/R	AUGER FOR MODEL 340, LEFT OR RIGHT HAND
7	FA 715 L/R	AUGER FOR MODEL 430, LEFT OR RIGHT HAND
-	FA 714L	AUGER FLIGHTING LEFT (SOLD BY FOOT) 13' NEEDED ON A 430
-	FA 714R	AUGER FLIGHTING RIGHT (SOLD BY FOOT) 1/2' NEEDED ON A 430
8	FA 101PB	PILLOW BLOCK BEARING, 1-1/4"
9	FA 102FB-4	4 BOLT FLANGE BLOCK BEARING, 1-1/2"
10	FA 107-3F	3 BOLT FLANGETTE
11	FA 205A	60BT32 SPROCKET, TAPER LOCK
11	FA 205A-10 (1000 RPM)	60BT42 SPROCKET, TAPER LOCK
12	FA 205B	2012 TAPER LOCK BUSHING, 1-1/4"
13	FA 312B	SF BUSHING, 1-1/4"
14	FA 312FA	SF BUSHING, 1-1/2"
15	FA 326BU	H BUSHING, 1-1/4"
16	FA 330B	SINGLE IDLER PULLEY, B BELT
17	FA 330C	SINGLE IDLER PULLEY, C BELT
18	FA 331BU	H BUSHING, 7/8"
19	FA 331S	SPRING, ELEVATOR DRIVE TIGHTENER
20	FA 361E	ELEVATOR DRIVE BELT, B61
---	FA 361EX	ELEVATOR DRIVE BELT, EXTRA DUTY
21	FA 396A	AUGER DRIVE BELT, CX 96
22	FA 402A	SHAFT, 1-1/4" X 10-1/2"
23	FA 405E	ELEVATOR DRIVE SHAFT, 7/8" X 11"

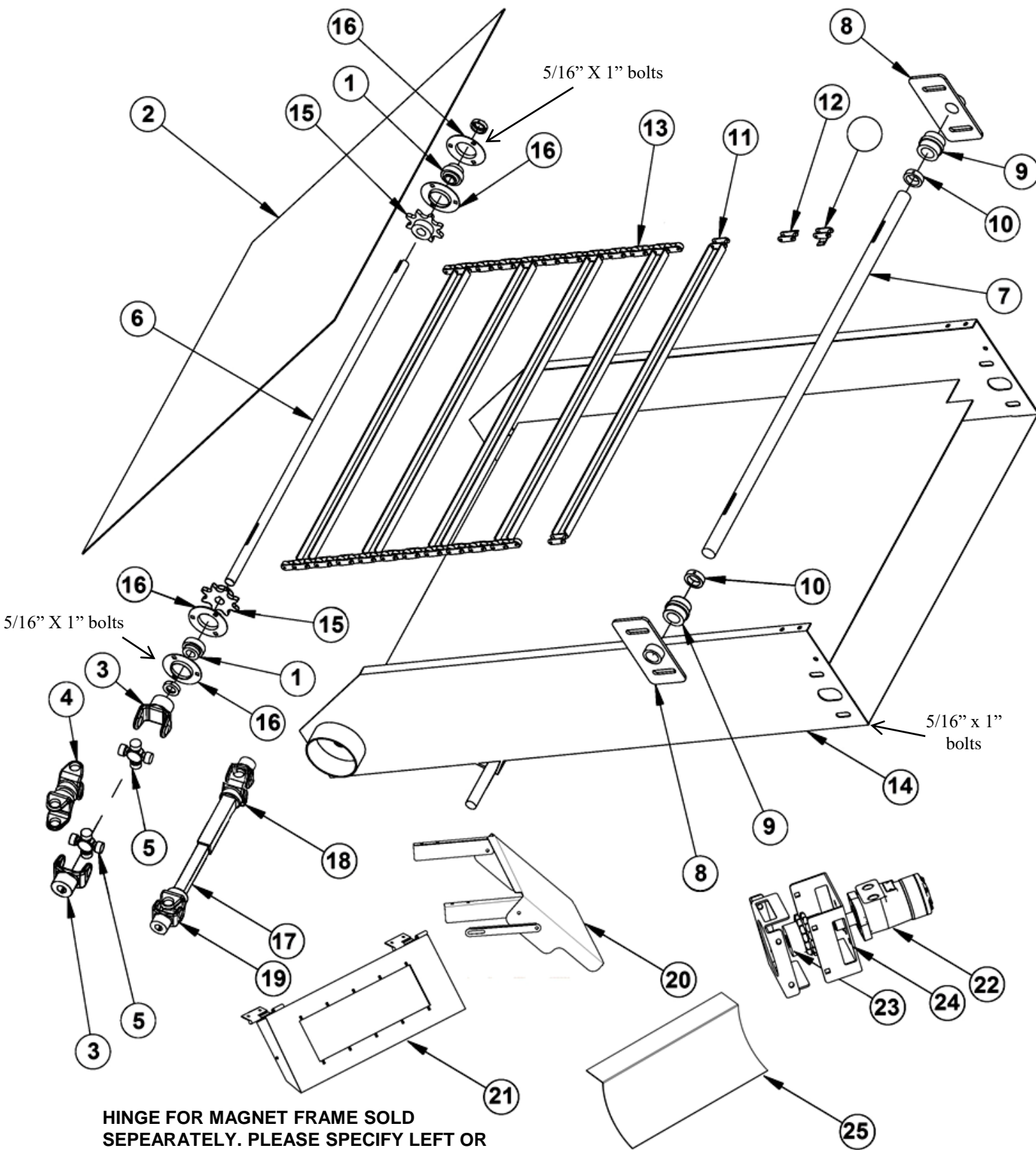

ITEM	P / N	DESCRIPTION
1	FA 107	7/8" BEARING
2	FA 350S	STEEL UNLOADING DOOR
3	FA 501	6 SERIES, 7/8" YOKE
4	FA 502	DOUBLE YOKE FOR MODEL 250
5	FA 505	6 SERIES CROSS & BEARING KIT
6	FA 510	SHAFT, 7/8" X 41"
7	FA 511	SHAFT, 1" X 38"
8	FA 512	SHAFT MOUNTING PLATE, UPPER ELEVATOR
9	FA 513	ELEVATOR IDLER ROLL
10	FA 514	SET COLLAR, 1"
11	FA 515	CHAIN SLAT WITH LINKS
12	FA 516	CHAIN LINK, SINGLE W/PIN
---	FA509CP	CONNECTION PIN ONLY FOR CHAIN
13	FA 523	CHAIN, 3' ELEVATOR
13	FA 524	CHAIN, 4' ELEVATOR
13	FA 525	CHAIN, 5' ELEVATOR
14	FA 533	ELEVATOR WELDMENT AND SPROCKETS, 3' ELEVATOR
14	FA 534	ELEVATOR WELDMENT AND SPROCKETS, 4' ELEVATOR
14	FA 535	ELEVATOR WELDMENT AND SPROCKETS, 5' ELEVATOR
14	FA 543	COMPLETE ELEVATOR, 3' (WITH CHAIN AND ROLLERS)
14	FA 544	COMPLETE ELEVATOR, 4' (WITH CHAIN AND ROLLERS)
14	FA 545	COMPLETE ELEVATOR, 5' (WITH CHAIN AND ROLLERS)
15	FA 762A	762 SPROCKET, 7/8" BORE
16	FA 107-3F	3 BOLT FLANGETTE
17	FA 504CU	ELEVATOR DRIVE SHAFT WITH BOTH YOKES, 430 & 340 FOR MODEL 340 CUT 5.5" FROM SHAFT AND TUBE.
18		Discontinued, use 17 above
19		Discontinued, use 17 above
20	FA 520EH	ELEVATOR HOOD AND BRACKETS
21	FA 748F	MAGNET FRAME SHOWN WITH HINGES SOLD SEPERATELY
22	FAC 509	HYDRAULIC MOTOR FOR TRAILER MOUNT
23	FAC 5230	MOTOR COUPLER (BOTH SPROCKETS AND CHAIN)
24	FA 518	MOUNT FOR HYDRAULIC MOTOR ON 430/340 (WELD ON)
25	FA 536ES	ELEVATOR SADDLE

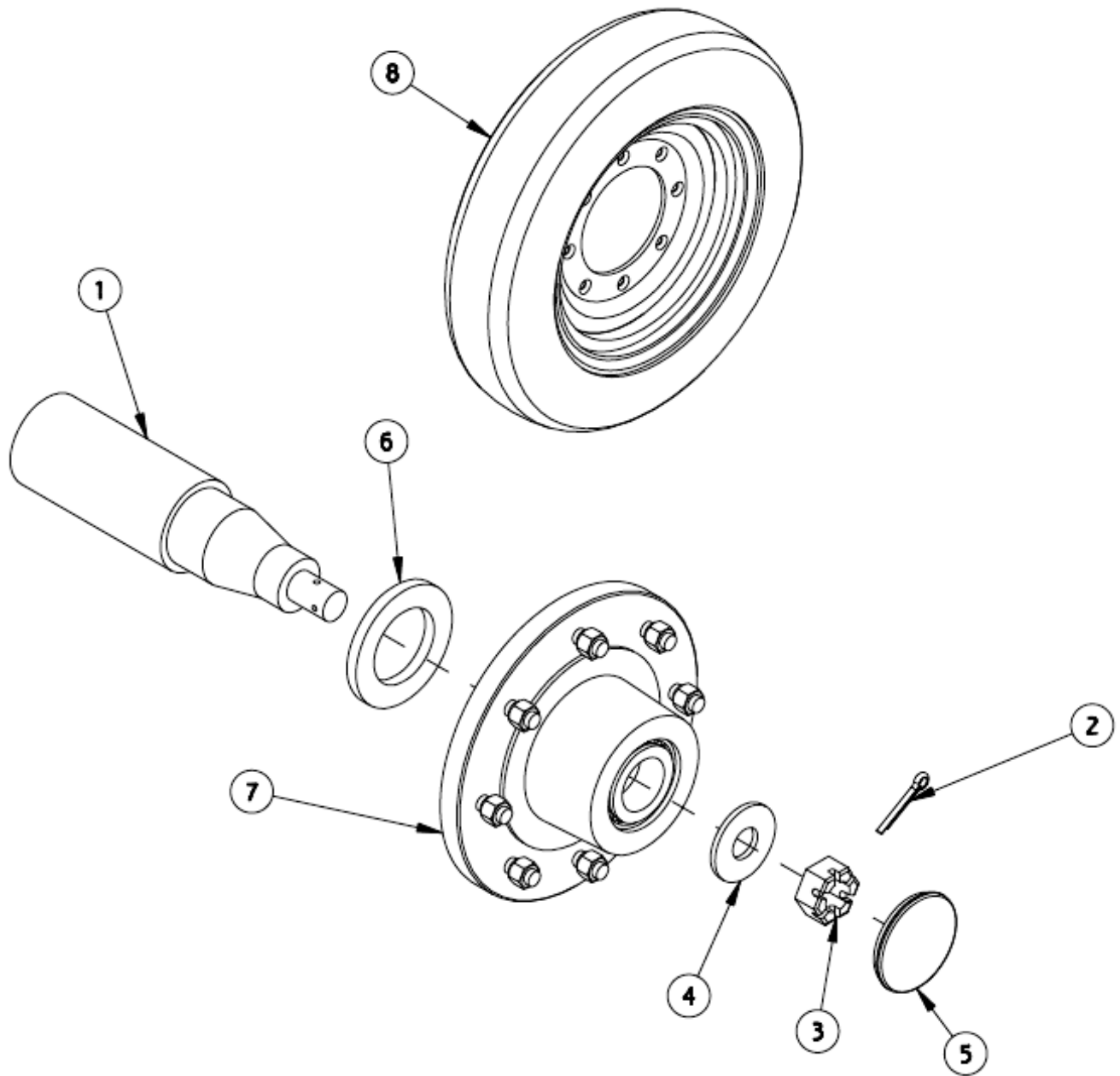

ITEM	P / N	DESCRIPTION
1	FA 600	SPINDLE, 2 3/4" FOR MODELS 250 & 340
2	FA 600K	SPLIT KEY FOR MODELS 250 & 340
3	FA 600N	SPINDLE NUT, FOR MODELS 250 & 340, 1" 14 THREAD
4	FA 600W	SPINDLE WASHER FOR MODELS 250 & 340
5	FA 601HC	HUB CAP FOR MODELS 250 & 340
6	FA 601SE	SEAL FOR MODELS 250 & 340
7	FA 602CA	COMPLETE HUB ASSEMBLY FOR MODELS 250 & 340
8	FA 620WH	RIM, C8 x 20" x 8"

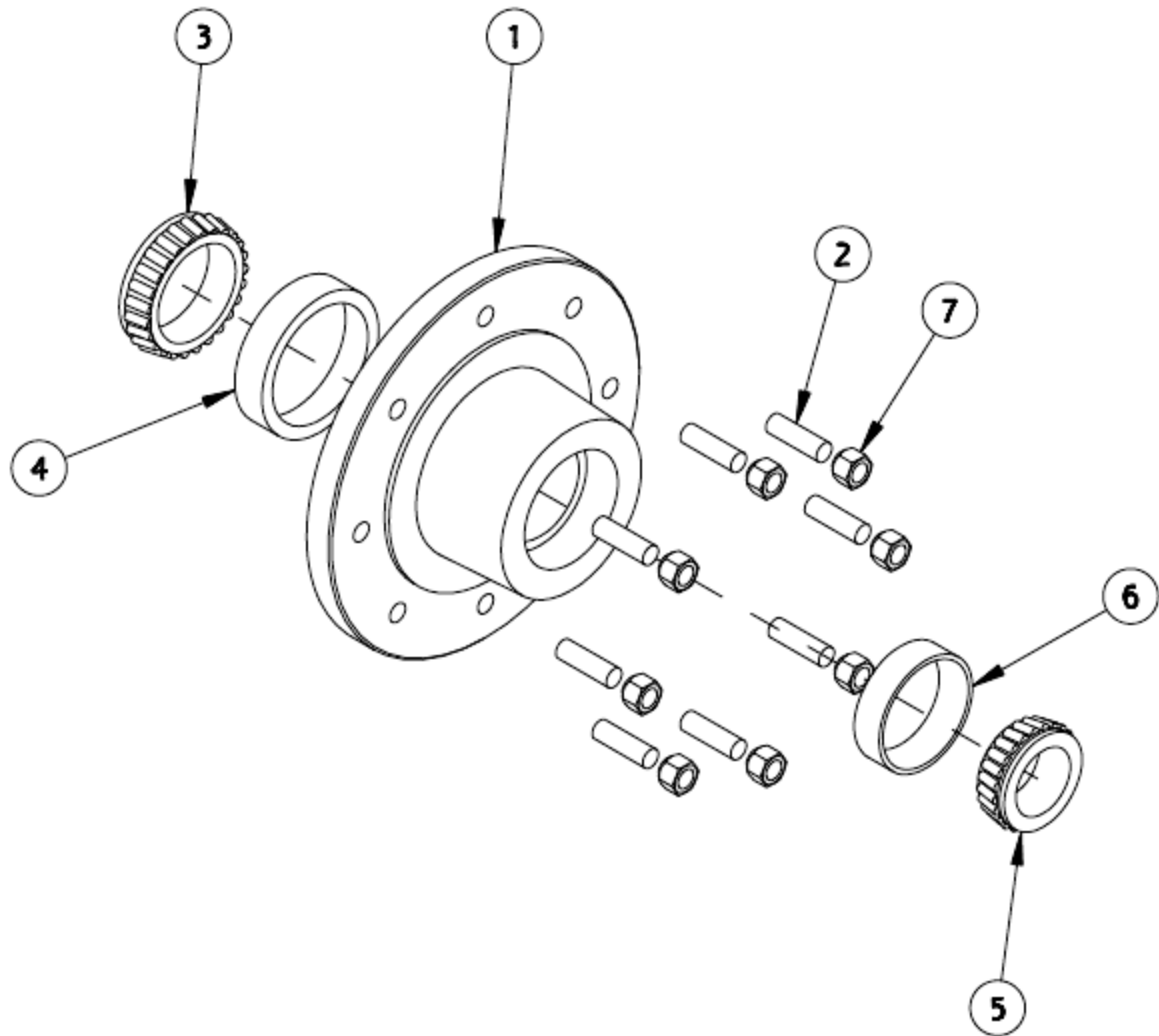

ITEM	P / N	DESCRIPTION
--	FA602CA	HUB ASSMBLY, COMPLETE WITH SEAL
1	FA 601	HUB, 8 ON 8 x 6 W/CUPS MODELS 250 & 340
2	FA 601HB	HUB BOLTS (STUDS), 8 USED, MODELS 250 & 340
3	FA 601IB	INNER CONE (BEARING) MODELS 250 & 340
4	FA 601IR	INNER CUP (RACE) MODELS 250 & 340
5	FA 601OB	OUTER CONE (BEARING) MODELS 250 & 340
6	FA 601OR	OUTER CUP (RACE) MODELS 250 & 340
7	FA 601WN	WHEEL NUT, 8 OF, MODELS 250 & 340

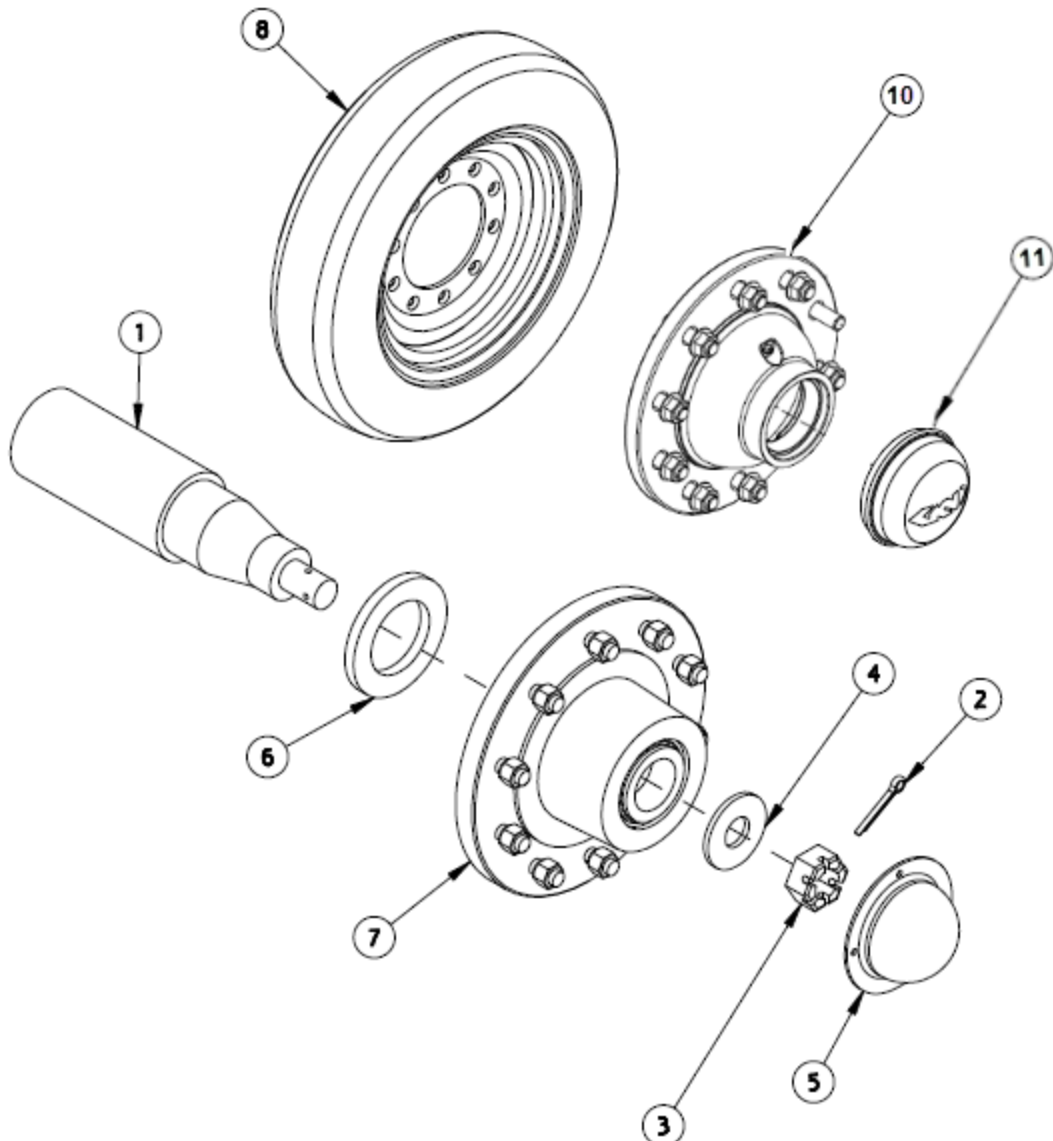

ITEM	P / N	DESCRIPTION
1	FA 620	SPINDLE , 430 WITH 10 BOLT RECTANGULAR AXLE
1	FA623	SPINDLE , 430 WITH 10 BOLT LATE 2013 ROUND AXLE
2	FA 620K	SPLIT KEY FOR MODEL 430 WITH 10 BOLT
3	FA 620N	SPINDLE NUT FOR MODEL 430 WITH 10 BOLT
4	FA 620W	SPINDLE WASHER FOR MODEL 430 WITH 10 BOLT
5	FA 621HC	HUB CAP, MODEL 430, 10 BOLT, SN < 2248 (bolt on)
6	FA 621SE	SEAL FOR MODEL 430 WITH 10 BOLT
7	FA 622CA	COMPLETE 10 BOLT HUB ASSM, MODEL 430 SN < 2248
8	FA 622WH	RIM, 13" x 22-1/2" x 10 x 11-1/4" x .871"
9	FA 621GAS	HUB CAP GASKET
10	FA622CA	COMPLETE 10 BOLT HUB ASSM, MODEL 430 SN > 2247
11	FA622HC	HUB CAP, MODEL 430, 10 BOLT, SN > 2247 (no bolts)

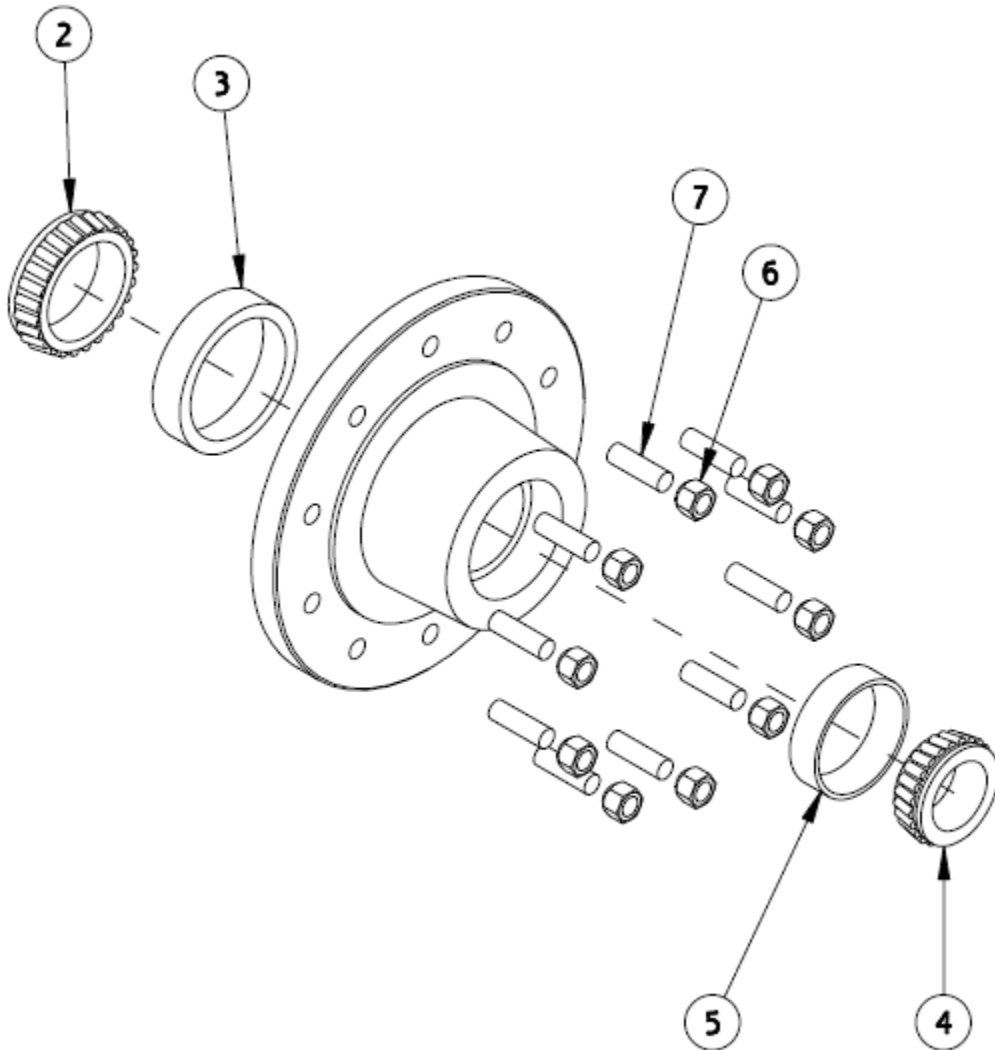

ITEM	P / N	DESCRIPTION
--	FA622CA	HUB ASSEMBLY, COMPLETE W/ SEAL
2	FA 621IB	INNER CONE (BEARING) MODEL 430
3	FA 621IR	INNER CUP (RACE) MODEL 430
4	FA 621OB	OUTER CONE (BEARING) MODEL 430
5	FA 621OR	OUTER CUP (RACE) MODEL 430
6	FA 621WN-C	WHEEL NUT, 10 OF, MODEL 430 (W/CHAMFER - EARLY STYLE)
6	FA 621WN	WHEEL NUT, 10 OF, MODEL 430 (FLAT FACE)
7	FA 622HB	HUB BOLT MODEL 430

ITEM	P / N	DESCRIPTION
1	FA 208	8048 SPROCKET FOR USE WITH A QD SIZE E BUSHING. DURING 2013 AND 2014 SOME MIXERS WERE BUILT WITH A SPROCKET THAT USED A TAPERLOCK BUSHING. SPROCKET FAC245 AND BUSHING FAC245H. THESE ARE DISCONTINUED.
2	FA 340	PLASTIC IDLER
3	FA 709 L/R	AUGER FOR MODEL 250, SPECIFY LEFT OR RIGHT HAND
3	FA 712 L/R	AUGER FOR MODEL 340, SPECIFY LEFT OR RIGHT HAND
3	FA 715 L/R	AUGER FOR MODEL 430, SPECIFY LEFT OR RIGHT HAND
4	FA 101FB-4	4 BOLT FLANGE BEARING, 1-1/4"
5	FA 102PB	PILLOW BLOCK BEARING, 1-1/2"
6	FA 103PB	PILLOW BLOCK BEARING, 2-3/16"
7	FA 104PB	PILLOW BLOCK BEARING , 2-15/16" (SPIRAL SUPPORT)
8	FA 207TS	8011 TIMING SPROCKET
9	FA 212SQR	SQUARE SPIDER SHIELD EARLIER MACHINES USED A TEAR DROP SHAPED SHIELD THAT IS OBSOLETE. MOUNTING THIS PART WILL REQUIRE DRILLING 4 HOLES TO INSTALL.
10	FA 212	SPIDER (It is recommended to replace the bolts with this part)
11	FA 208B	QD E BUSHING, 2-3/16
---	FA212BLT	BOLT FOR SPIDER GEAR AND 8048 SPROCKET
12	FA 214-80	81" 80 CHAIN (82 ROLLER)
13	FA 403BS	SHAFT, 1-1/2" X 12"
14	FA 404BS	SHAFT, 2-3/16" X 13"
15	FA 406S	14 SERIES, 1-1/2" YOKE
16	FA 407S	14 SERIES, YOKE TUBE WELD
17	FA 408S	14 SERIES CROSS & BEARING KIT
18	FA 203TP	8011 TIMING PLATE
19	FA 203B	1610 X 1-1/2" TAPER LOCK BUSHING WITH AN OD=2-3/8" MACHINES WITH A SOLID (NOT WELDED) TIMING PLATE USED AN FA207H - 2012 X 1-1/2" TAPERLOCK BUSHING WITH AN OD=2-3/4"

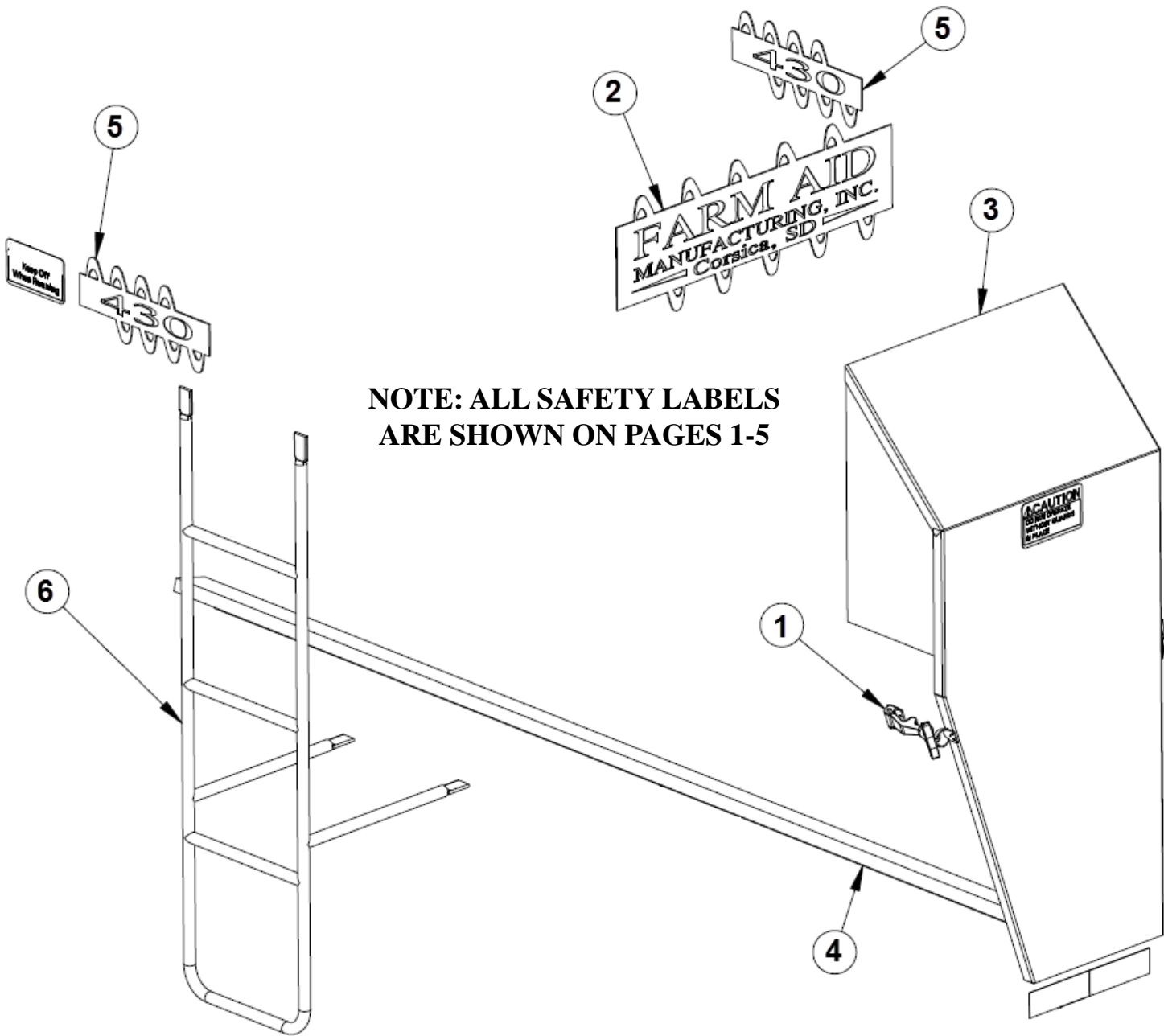

ITEM	P / N	DESCRIPTION
1	FA 001	SHIELD TIE, COMPLETE (2 USED)
2	FA 356	DECAL, FARM AID EQUIPMENT
3	FA 802	SHIELD, REAR DRIVE, SPECIFY LEFT OR RIGHT HAND DISCHARGE
4	FA 8250	GUARD DRIVELINE TO REAR, MODEL 250
4	FA 8340	GUARD DRIVELINE TO REAR, MODEL 340
4	FA 8430	GUARD DRIVELINE TO REAR, MODEL 430
5	FA 360-model	DECAL, SPECIFY MODEL (250, 340,430)
6	FA 090L	LADDER

TYPICALLY IF A PART NUMBER HAS AN "F" OR A "B" AS A SUFFIX IT DENOTES FRONT OR BACK. ON RIGHT HAND DISCHARGE MIXERS PARTS IN THE MIXING BOX ARE REVERSED FRONT TO BACK

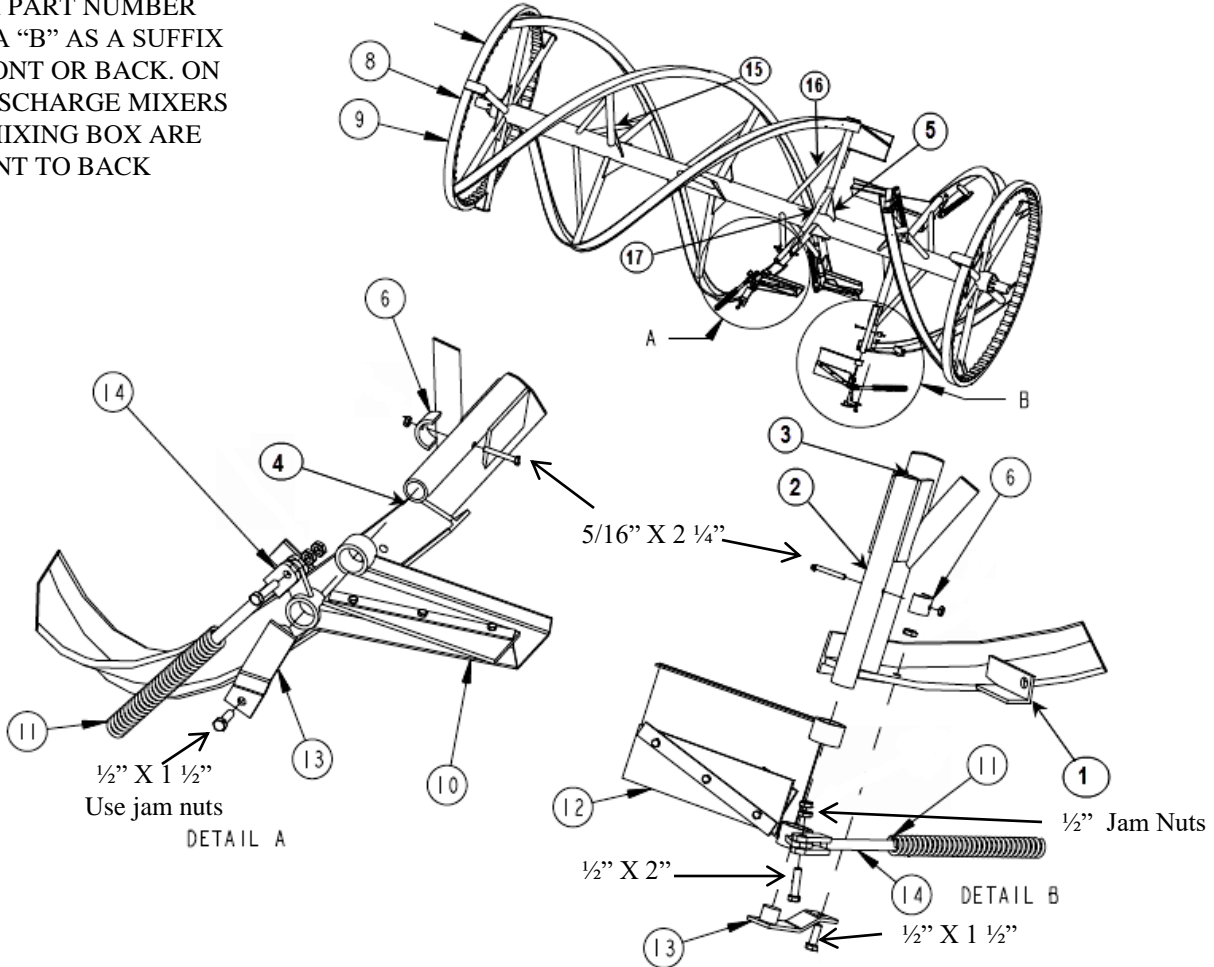

ITEM	P / N	DESCRIPTION
1	FA 335SRG	SPRING ROD GUIDE
2	FA 335P	KICKER MOUNTING PIPE WITH "FLAGS"
3	FA 335PC	KICKER MOUNTING PIPE CAP
4	FA 335KS	KICKER STOP
5	FA 817	MAIN SPIRAL GUSSET
6	FA 336	KICKER KEEPER
8	FA822 FA824 FA825	250 SPIRAL SPECIFY LEFT OR RIGHT AND IF IT IS DRIVEN ON BOTH ENDS 340 SPIRAL SPECIFY LEFT OR RIGHT 430 SPIRAL SPECIFY LEFT OR RIGHT
9	END RING	3" CHANNEL PLUS ALL COGS AND WRAP ON THE OUTSIDE
10	FA 335B	BACK KICKER 250-550 MODELS w/ LEFT HAND DISCHARGE
11	FA 332C	COMPRESSION SPRING
12	FA 335F	FRONT KICKER 250-550 MODELS w/ LEFT HAND DISCHARGE
13	FA335KC	KICKER CAP
14	FA 335SR	KICKER SPRING ROD
15	FA 820	2" SPOKE
16	FA 819	BRACE PIPE 1 1/4" x 27"
17	FA 819KP	KICKER BRACE PIPE 1 1/4" x 24"

LEFT

TYPICALLY IF A PART NUMBER HAS AN "F" OR A "B" AS A SUFFIX IT DENOTES FRONT OR BACK. BUT ON RIGHT HAND DISCHARGE MIXERS PARTS IN THE MIXING BOX ARE REVERSED FRONT TO BACK

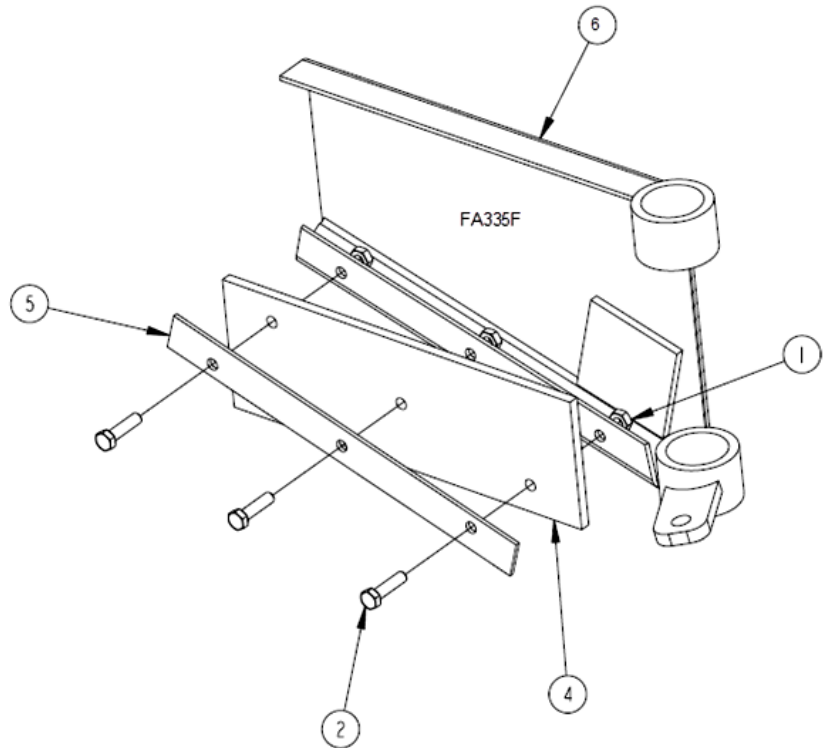
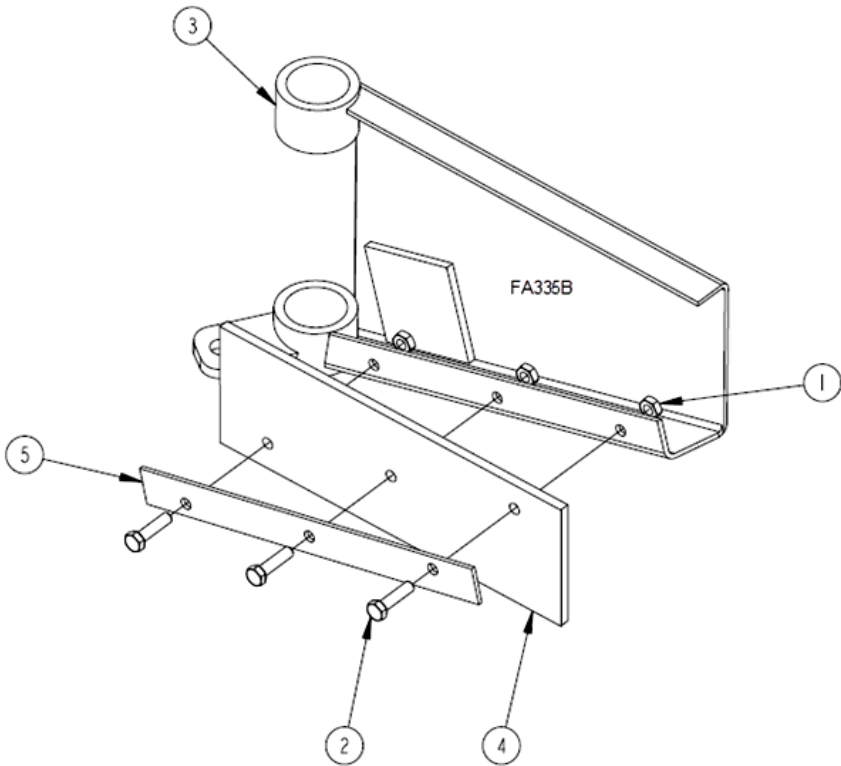

ITEM	PART NUMBER	DESCRIPTION
1	-----	5/16 18NC HEX NUT
2	-----	HEX HD BOLT, 5/16 18NC X 1.00
3	FA 335B	BACK KICKER, COMPLETE W/BELTING, LEFT HAND
4	FA 335KB	KICKER BELT
5	FA335KS	BOLT STRAP, KICKER
6	FA 335F	FRONT KICKER, COMPLETE W/BELTING, LEFT HAND

LEFT

TYPICALLY IF A PART NUMBER HAS AN "F" OR A "B" AS A SUFFIX IT DENOTES FRONT OR BACK. BUT ON RIGHT HAND DISCHARGE MIXERS PARTS IN THE MIXING BOX ARE REVERSED FRONT TO BACK

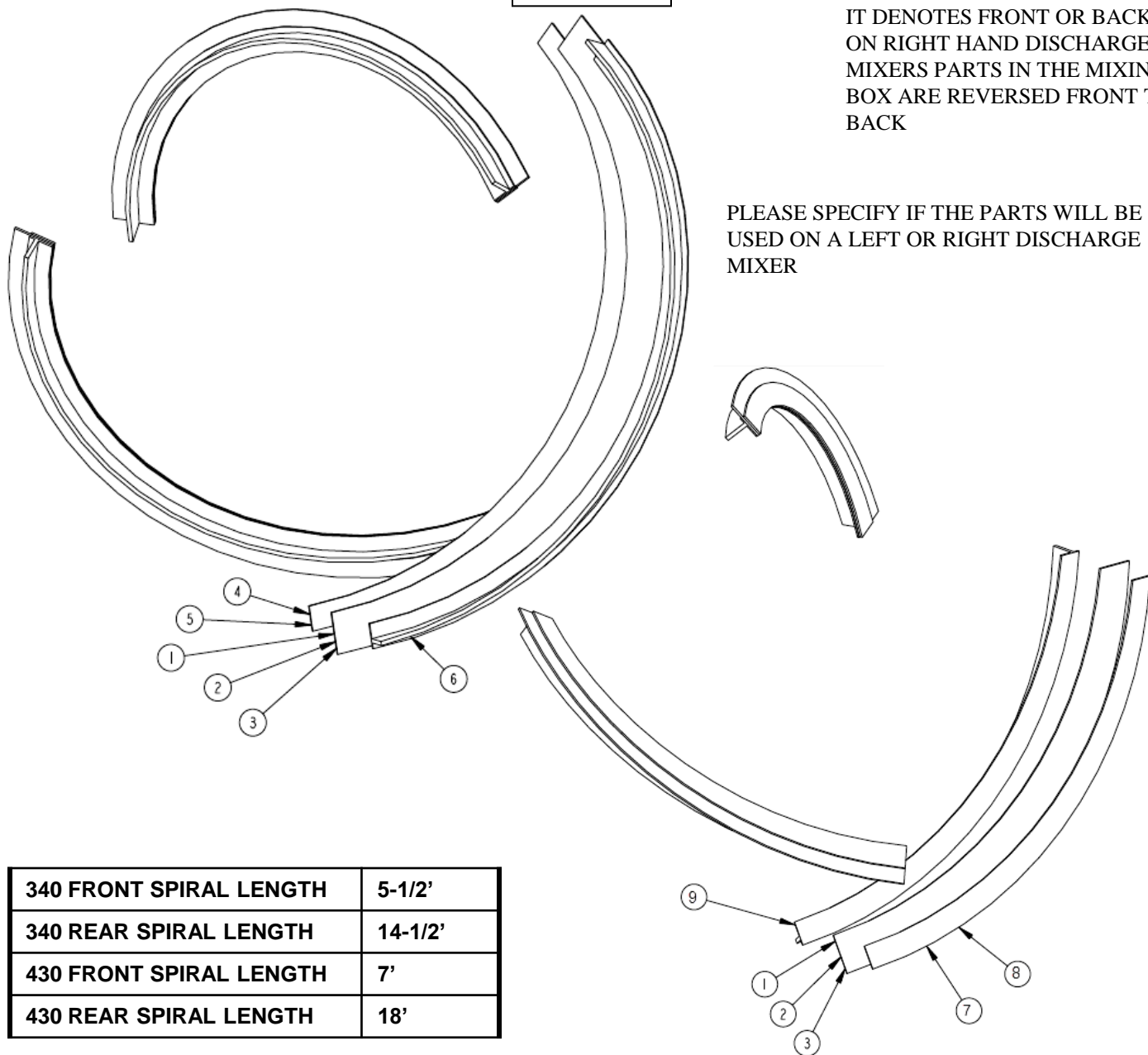

PLEASE SPECIFY IF THE PARTS WILL BE USED ON A LEFT OR RIGHT DISCHARGE MIXER

ITEM	P / N	DESCRIPTION
1	FA 700B	SWEEP CLEAN BELT, 250, uses up to (17) 5/16 X 1.5" bolts
2	FA 701B	SWEEP CLEAN BELT, 340, uses up to (22) 5/16 X 1.5" bolts
3	FA 702B	SWEEP CLEAN BELT, 430, uses up to (26) 5/16 X 1.5" bolts
4	FA 830FF	FRONT SPIRAL FACE MATERIAL, BY FT, RT
5	FA 830FF-H	FRONT SPIRAL FACE MATERIAL W / HOLES, BY FT, RT
6	FA 830FS	FRONT SPIRAL SUPPORT MATERIAL, BY FT, RT
7	FA 830BF	BACK SPIRAL FACE MATERIAL, BY FT,RT
8	FA 830BF-H	BACK SPIRAL FACE MATERIAL W / HOLES, BY FT,RT
9	FA 830BS	BACK SPIRAL SUPPORT MATERIAL, BY FT, RT

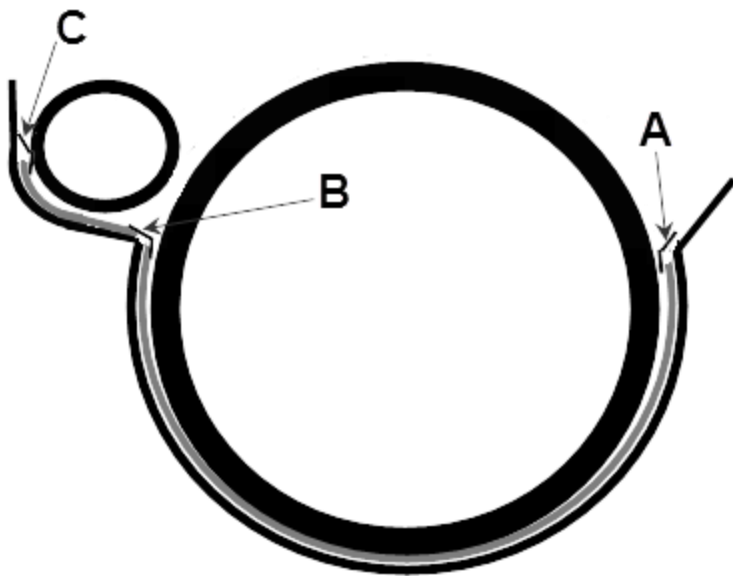

STRIP CHART			
MODEL	A	B	C
430 front	FA8510	FA8610	FA7520
430 middle	FA7520	FA8620*	FA7520
430 back	FA8530	FA8630	FA8730
340 front	FA8510	FA8615	FA7520
340 middle	-----	FA8625*	-----
340 back	FA8510	FA8630	FA8720
250 front	FA8510	FA8618	FA7520
250 middle	-----	FA8628	-----
250 back	FA8530	FA8630	FA8730

•* Before ordering 430 or 340 “B” middle please measure the distance from the end of the auger trough to the two top rear bolts on this part. The first bolt hole should be 2” and the second one should be 17”. If the holes are not 2” and 17” please call the factory for a special part.

P / N	DESCRIPTION
FA731K	250 POLY FLOOR LINER KIT SPECIFY LEFT OR RIGHT
FA731AP	250 POLY AUGER LINER KIT SPECIFY LEFT OR RIGHT
FA731-1	250 FRONT POLY FLOOR LINER SPECIFY LEFT OR RIGHT
FA731-2	250 CENTER POLY FLOOR LINER SPECIFY LEFT OR RIGHT
FA731-3	250 BACK POLY FLOOR LINER SPECIFY LEFT OR RIGHT
FA732KR	340 POLY FLOOR LINER KIT
FA732APL	340 POLY AUGER LINER KIT
FA732-1L	340 FRONT POLY FLOOR LINER
FA732-2L	340 CENTER POLY FLOOR LINER
FA732-3L	340 BACK POLY FLOOR LINER
FA733KL	430 POLY FLOOR LINER KIT
FA733APL	430 POLY AUGER LINER KIT
FA733-1L	430 FRONT POLY FLOOR LINER
FA733-2L	430 2ND POLY FLOOR LINER
FA733-3L	430 3RD POLY FLOOR LINER
FA733-4L	430 BACK POLY FLOOR LINER
FA757	CARRIAGE BOLT (250-Qt 50; 340-Qt 50; 430-Qt 58---40 for floor only)
FA756B	ELEVATOR BOLT (250-Qt 53; 340-Qt 53; 430-Qt 64)
FA754	TORX SCREW 1/4 X 1-1/2 (250-Qt 5; 340-Qt 5; 430-Qt 6)