



560 and 680 Parts Manual

There have been four series of drive mechanism on the 560 & 680 model Farm Aid TMR mixers.

Series I has different front drive between the 680 and the 560. The drive in the rear is shared between the 560 and 680 with the exception of chain length. S/N less than 21489

Series II 680 change only, the final drive chain and sprockets were changed from #100 to #120. S/N 21489 to approximately S/N 24883

Series III 680 change only, the front sprockets were changed from 20 tooth-60 tooth combination to a 16 tooth-48 tooth combination (same as 560). S/N 24883 to approximately S/N 25443

Series IV 560 and 680 change, UHMW rollers replace both the chain reversing sprockets and the slack adjusting sprockets that were not already UHMW rollers. From approximately S/N 25443 forward.

Please note that these S/N are approximate. Please examine the machine you are working on to determine which series machine you are working on before purchasing parts

This page is left blank intentionally

Table of Contents

Page	Content
1	External parts in front - Left
2	External parts in front - Right
3	Scale and Support - Left and Right
4	PTO - Left and Right
5	Belt Drive - Left
6	Belt Drive - - Right
7	680 Front Auger Drive - Left
8	680 Front Auger Drive - Right
9	560 Front Auger Drive - Left
10	560 Front Auger Drive - Right
11	680 Rear Drive - Left
12	680 Rear Drive - Right
13	560 Rear Drive - Left
14	560 Rear Drive - Right
15	Elevator - Left and Right
16	Elevator Chain - Left and Right
17	Spiral - Left and Right
18	Kicker With Belt - Left and Right
19	Back Spiral and Sweep –Left and Right
20	Back Sweep Kit - Left and Right
21	Spindle & Hub – Left and Right
23	Hub with Bearings – Left and Right
24	Rear External Parts – Left and Right
25	Poly Liners - Left
26	Poly Liners - Right

EXTERNAL PARTS IN FRONT, MODEL 560 & 680 LEFT HAND DISCHARGE

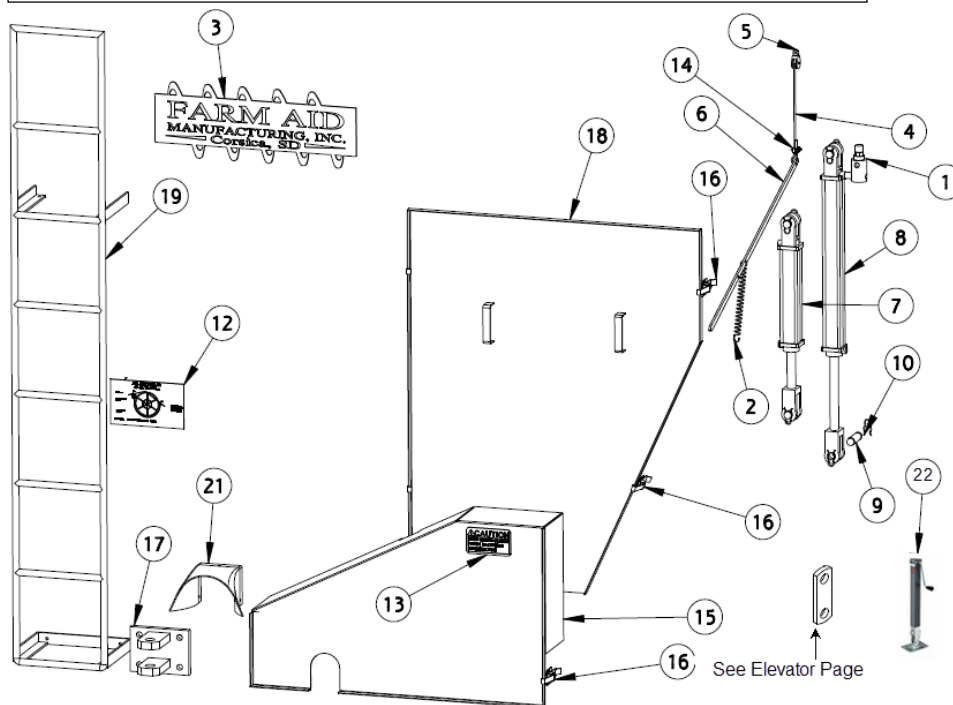

ITEM	PART NUMBER	DESCRIPTION
1	FA-020	Bypass Valve
2	FA-277	Spring, Door Indicator
3	FA-356	Decal, Farm Aid Equipment, Inc. Mfg
4	FA-541	Cable, Indicator Bar
5	FA-800	Pulley, Indicator Bar
6	FA-353-34	Door Indicator Bar, Model 560 & 680
7	FA-20-10	Hyd Cylinder, 2.00 Bore X 10.0 Stroke -- Repair Kit is FA639572
8	FA-20-24	Hyd Cylinder, 2.0 Bore X 24.0 Stroke -- Repair Kit is FA639572
9	FA-352P	Cylinder Pin
10	FA-352PC	Retainer, Cylinder Pin
	FAC005A	Door Seal, automotive style
12	FA-355R	Decal, Fill Level,
13	FA-358B	Decal, "Caution: Keep guard closed when machine is in operation"
14	FA-541C	Cable Clamp
15	FAC-009	PTO Drive Shield, Model 680/560
16	FAC-010	Shield Tie
17	FAC-604	Hitch Replacement --Wear Plate Only FA 603
18	FAC-006F	Large Shield, Front, Model 560/680, Left or Right Hand
19	FAC-090L	Ladder, Model 560 & 680 (Specify Model)
21	FAC-411B	Rubber Guard, PTO
22	FAC-604S	Jack, Sidewinder, Tube mount late 2013 change
	FAC-604K	This is a kit that contains the side-winding jack, mounting plate and storage tube. This requires welding to install. This replaces the large bolted on jack and increases ground clearance.

EXTERNAL PARTS IN FRONT, MODEL 560 & 680 RIGHT HAND DISCHARGE

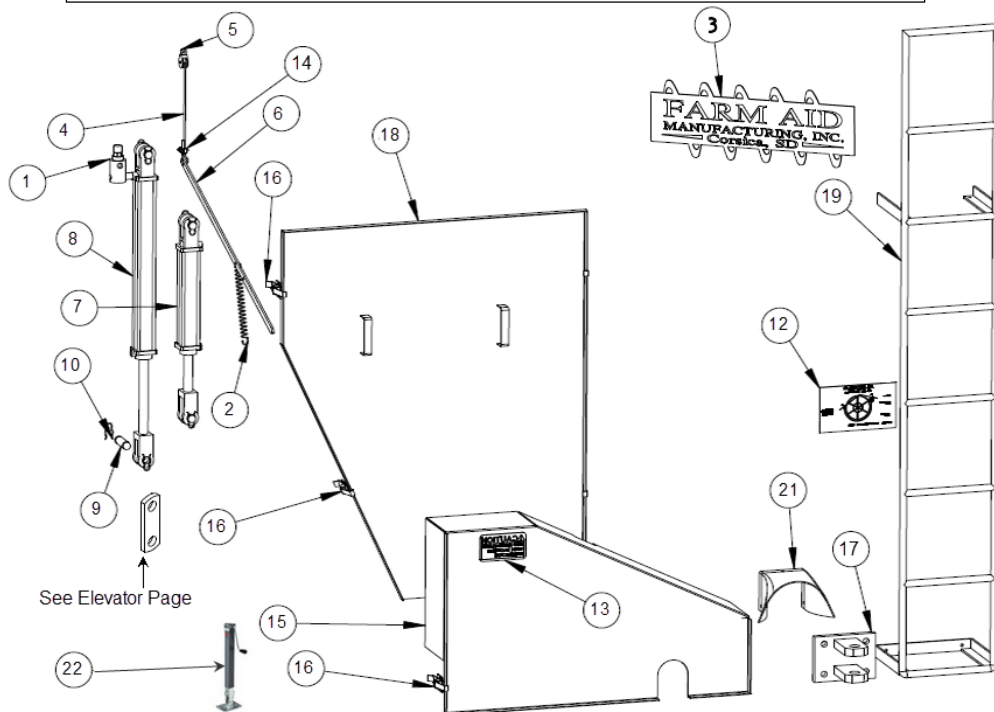

ITEM	PART NUMBER	DESCRIPTION
1	FA-020	Bypass Valve
2	FA-277	Spring, Door Indicator
3	FA-356	Decal, Farm Aid Equipment, Inc. Mfg
4	FA-541	Cable, Indicator Bar
5	FA-800	Pulley, Indicator Bar
6	FA-353-34	Door Indicator Bar, Model 560 & 680
7	FA-20-10	Hyd Cylinder, 2.00 Bore X 10.0 Stroke -- Repair Kit is FA639572
8	FA-20-24	Hyd Cylinder, 2.0 Bore X 24.0 Stroke -- Repair Kit is FA639572
9	FA-352P	Cylinder Pin
10	FA-352PC	Retainer, Cylinder Pin
	FAC005A	Door Seal, automotive style
12	FA-355R	Decal, Fill Level,
13	FA-358B	Decal, "Caution: Keep guard closed when machine is in operation"
14	FA-541C	Cable Clamp
15	FAC-009	PTO Drive Shield, Model 680/560
16	FAC-010	Shield Tie
17	FAC-604	Hitch Replacement --Wear Plate Only FA 603
18	FAC-006F	Large Shield, Front, Model 560/680, Left or Right Hand
19	FAC-090L	Ladder, Model 560 & 680 (Specify Model)
21	FAC-411B	Rubber Guard, PTO
22	FAC-604S	Jack, Sidewinder, Tube mount late 2013 change
	FAC-604K	This is a kit that contains the side-winding jack, mounting plate and storage tube. This requires welding to install. This replaces the large bolted on jack and increases ground clearance.

**ASSEMBLY, 560 & 680 SCALE and SUPPORT
RIGHT AND LEFT DISCHARGE**

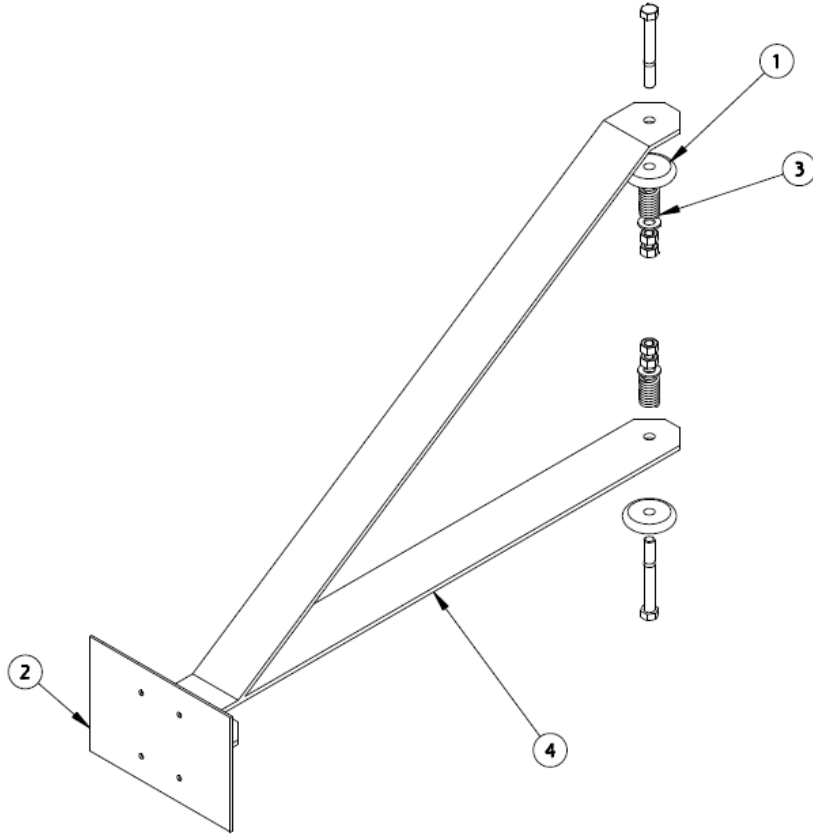

ITEM	PART NUMBER	DESCRIPTION
1	FA-135	Shock Absorber
2	FA-130B	Scale Mount Bracket
3	FA-131S	Compression Spring
4	FAC-13SIB	Scale Support
	SWT17807-0108	Rubber Mounts for Weigh-Tronix scales
	SWT12339-0015	Scale taper Bracket for Weigh-Tronix
	SWT21594-0370	2.50" Weigh-Tronix Weigh Bar
	SWT19219-0015	Summing Box Assy {Weigh Tronix J Box }
	SWT19266-0041	Power Cable, Weigh-Tronix
	SWT23581-0017	5 pin pig tale for weigh tronix bar
	SWT16662-0013	4 pin pig tale for Weigh-Tronix bar
	SDS403335	Power cord - DigiStar
	SDS404254	Junction box - DigiStar
	SDS141837	cable - 30' J box
	SDS146110	2.50" Digi-Star Weigh Bar (30' cable)
	Call	Pigtail for Digi-Star Weigh Bar

560 & 680 PTO
LEFT AND RIGHT DISCHARGE

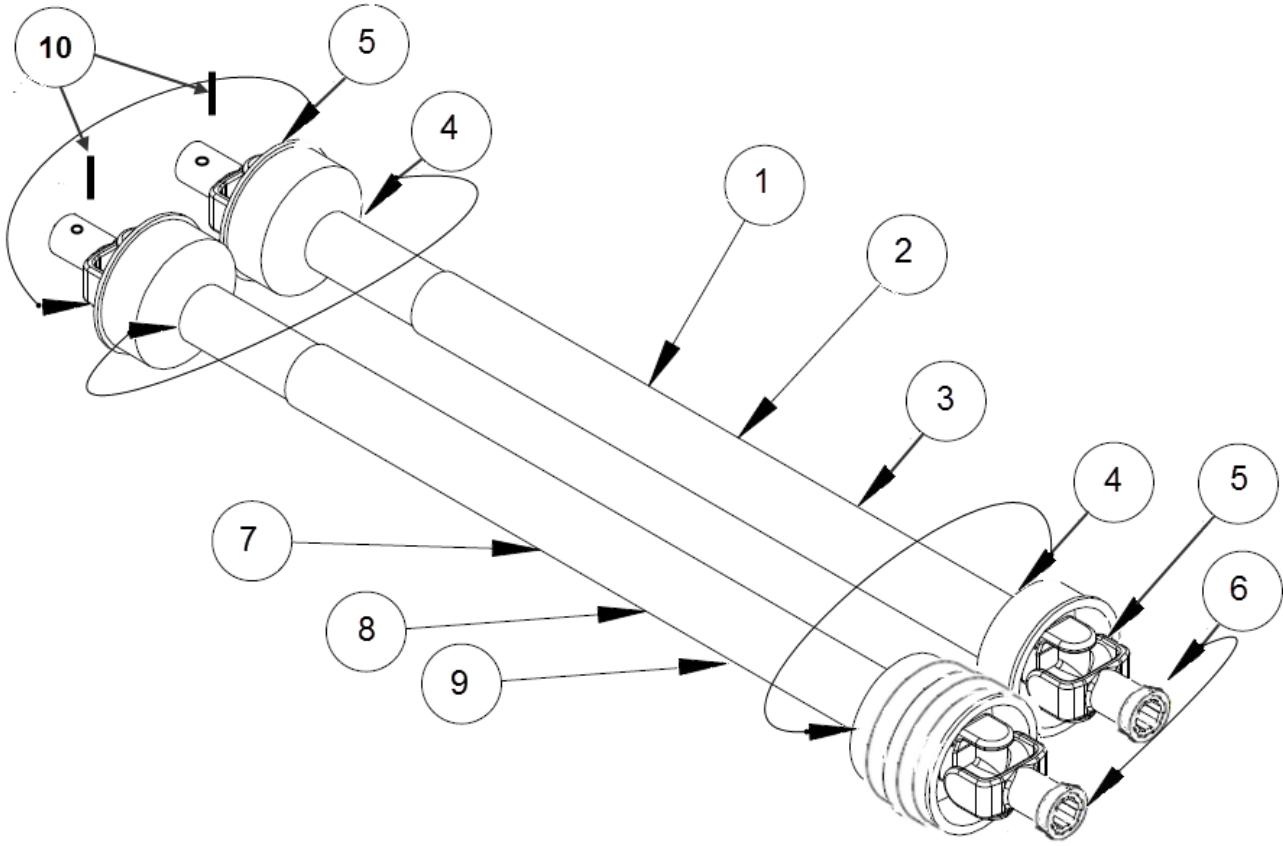

ITEM	PART NUMBER	DESCRIPTION
1	FAC413-21	Complete PTO Shaft, 1000 RPM
2	FAC413-06	Complete PTO Shaft, 540 RPM
3	FAC415C	Complete PTO Shield with Bearing
4	FAC414	PTO Shield Nylon Bearing kit
5	FAC411	Cross and Bearing Kit Fits both end of standard shaft and mixer end of CV shaft
6	FA417W	PTO snap ball yoke repair kit
7	FAC412-21	Complete CV PTO Shaft, 1000 RPM
8	FAC412-06	Complete CV PTO Shaft, 540 RPM
9	FAC408C	Complete CV PTO Shield with Bearing
10	FAC412RP	Roll Pin, 5/16" X 2.5"
10	FAC412RP-1/4"	Roll Pin, 1/4" X 2.5" Starting with S/N 1072

**560 & 680 BELT DRIVE
LEFT HAND DISCHARGE**

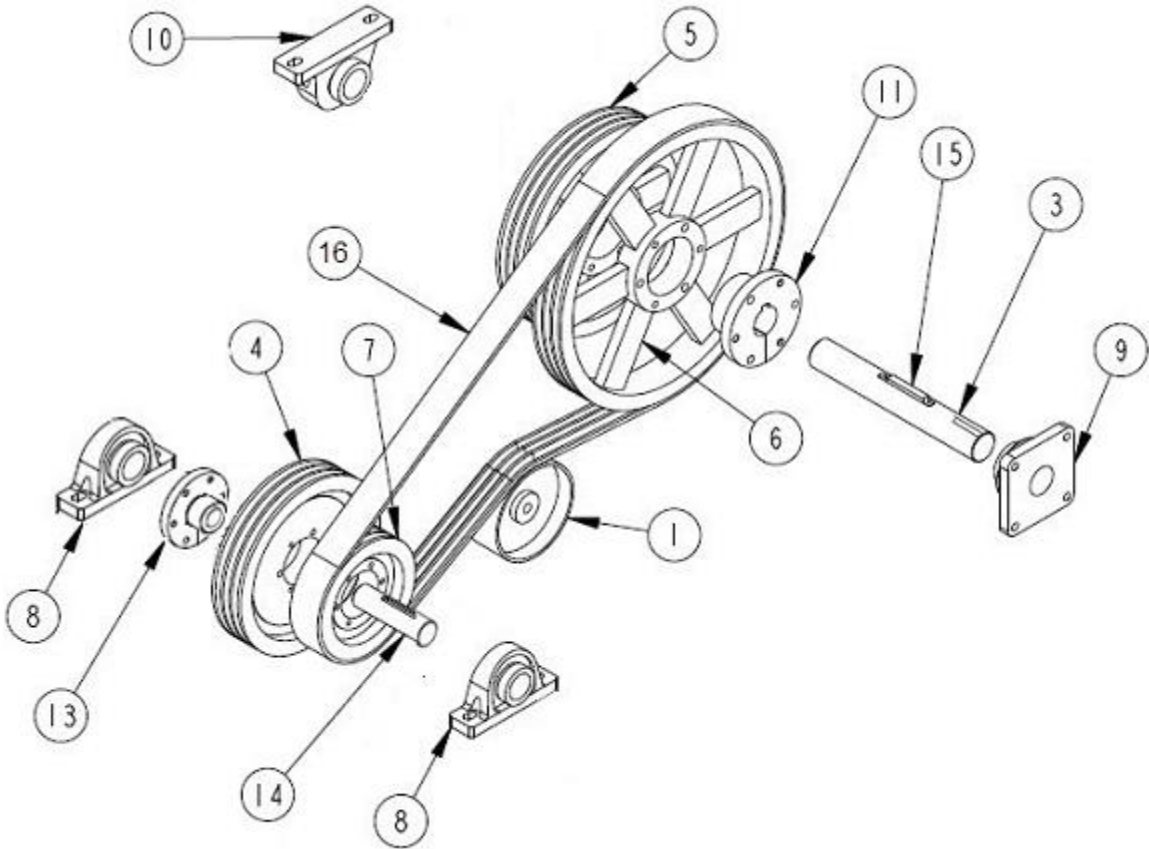

ITEM	PART NUMBER	DESCRIPTION
1	FAC-225	S25252A Idler Pulley
3	FAC-403	Shaft, 1-15/16 Dia X 13-3/4
4	FAC-3511	Pulley, 3G5V 11.8 Dia., 540 RPM
5	FAC-3514	Pulley, 3G5V 14.0 Dia., 540 RPM
6	FAC-3518	Pulley, 3G5V 18.7 Dia., 1000 RPM
7	FAC-3580	Pulley, 3G5V 8.0 Dia., 1000 RPM
8	FAC-105PB	Pillow Block BRG, 1-3/4 W/Lock Collar
9	FAC-106FB-4	Flange BRG, 4 Bolt, 1-15/16 W/Lock Collar
10	FAC-106PB	Pillow Block Brg, 1-15/16 W/Lock Collar
11	FAC-215E	E Bushing, 1-15/16
13	FAC-313H	QD-SF Bushing, 1-3/4
14	FAC-449	Shaft, 1-3/4 X 12
15	FAC-401K	Sq. Key, 1/2 X 3
16	FAC-5-1000	V-Belt, 3-5V
	FAC-226	Belt Idler Support
		Belt Idler Support shaft (8" X 0.75")
	FA412U	U-Bolt

**560 & 680 BELT DRIVE
RIGHT HAND DISCHARGE**

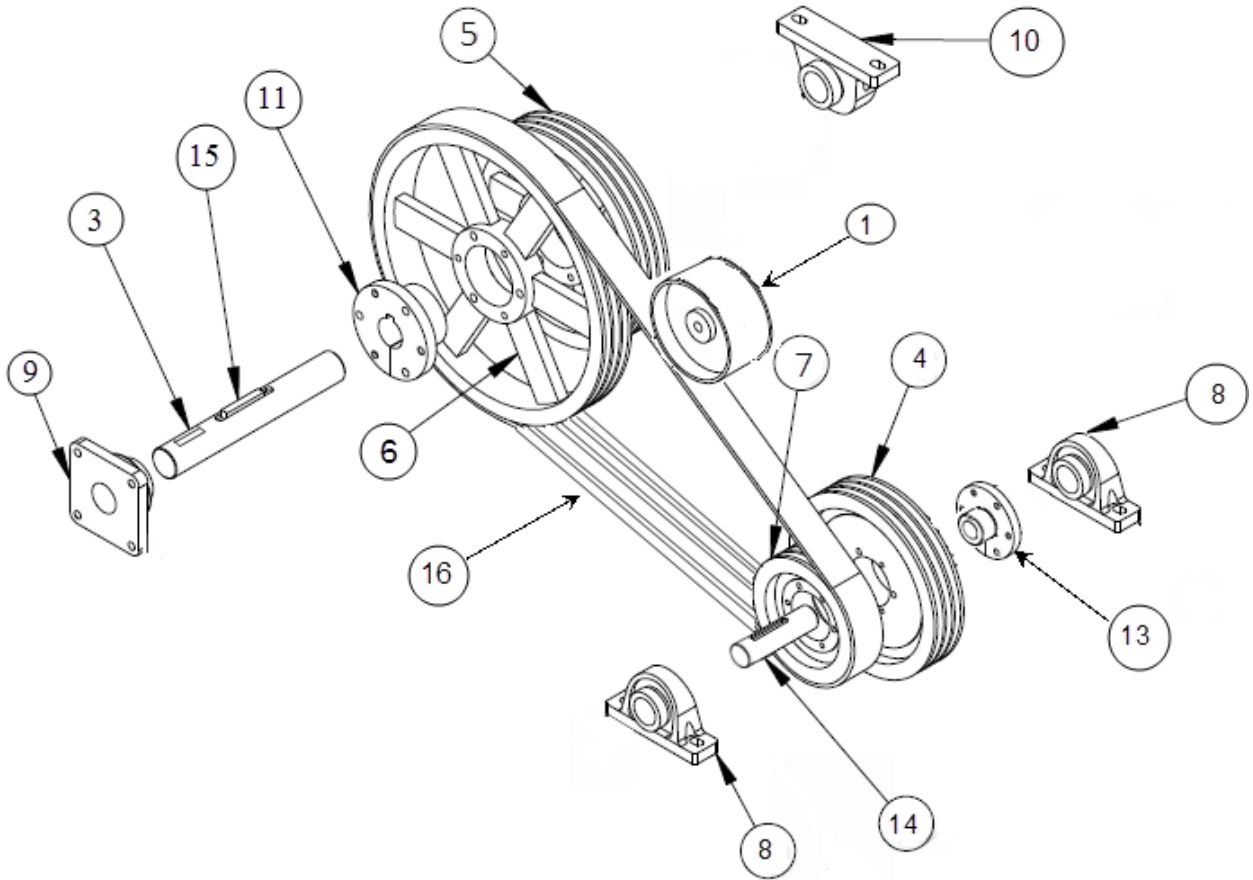

ITEM	PART NUMBER	DESCRIPTION
1	FAC-225	S25252A Idler Pulley
3	FAC-403	Shaft, 1-15/16 Dia X 13-3/4
4	FAC-3511	Pulley, 3G5V 11.8 Dia., 540 RPM
5	FAC-3514	Pulley, 3G5V 14.0 Dia., 540 RPM
6	FAC-3518	Pulley, 3G5V 18.7 Dia., 1000 RPM
7	FAC-3580	Pulley, 3G5V 8.0 Dia., 1000 RPM
8	FAC-105PB	Pillow Block BRG, 1-3/4 W/Lock Collar
9	FAC-106FB-4	Flange BRG, 4 Bolt, 1-15/16 W/Lock Collar
10	FAC-106PB	Pillow Block Brg, 1-15/16 W/Lock Collar
11	FAC-215E	E Bushing, 1-15/16
13	FAC-313H	QD-SF Bushing, 1-3/4
14	FAC-449	Shaft, 1-3/4 X 12
15	FAC-401K	Sq. Key, 1/2 X 3
16	FAC-5-1000	V-Belt, 3-5V
	FAC-226	Belt Idler Support
		Belt Idler Support shaft (8" X 0.75")
	FA412U	U-Bolt

680 FRONT AUGER DRIVE
LEFT HAND DISCHARGE

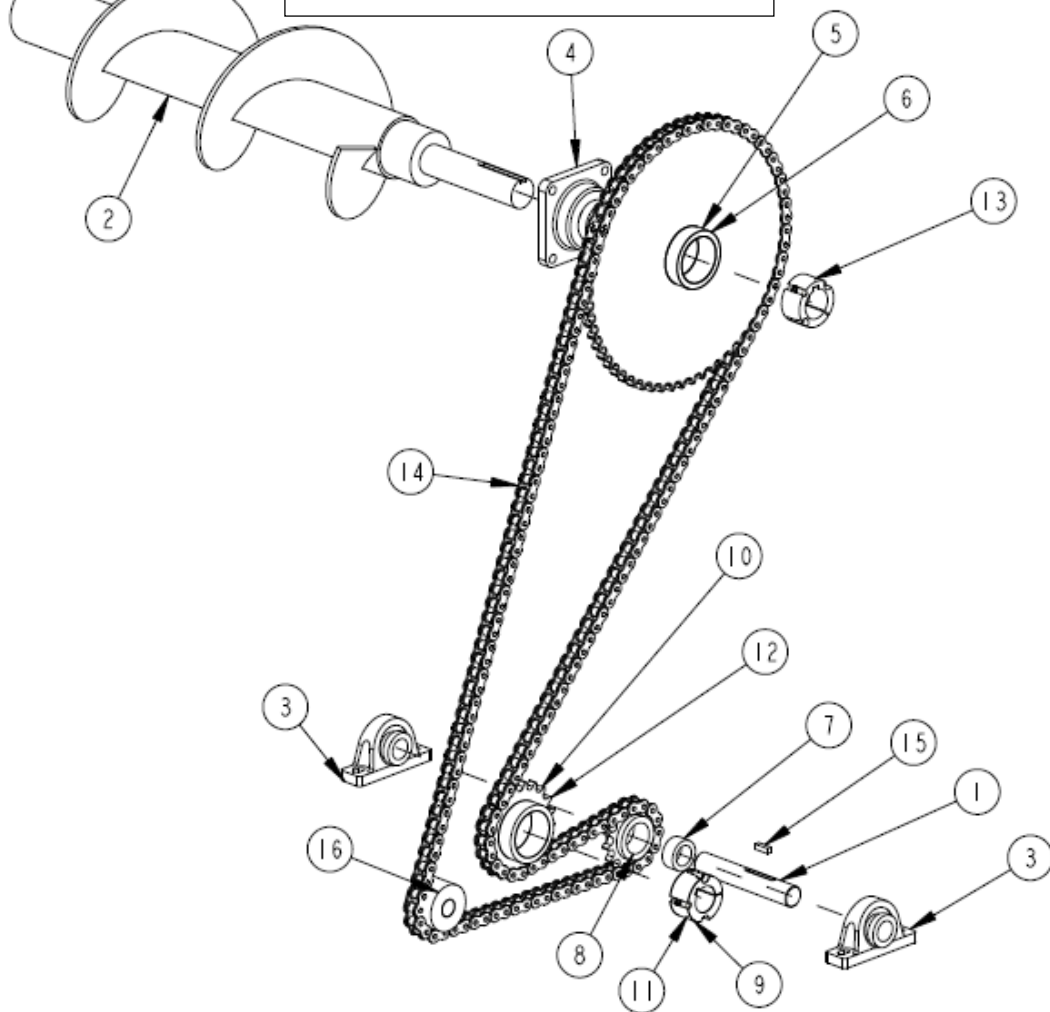

I & II	III	IV	ITEM	PART NUMBER	DESCRIPTION
X	X		1	FAC-406	Shaft, 1-1/2 X 9
X	X	X	2	FAC-818	Auger, Specify Left or Right Hand
X	X		3	FA102PB	Bearing, 1-1/2" Pillow Block
X	X	X	4	FAC-108FB-4	Flange Brg, 4 Bolt, 2-3/16
	X	X	5	FAC-248	Sprocket, 48T-80, Taper Lock
X			6	FAC-125	Sprocket, 60T-80, Taper Lock
X	X		7	Not Available	No longer needed with new style #8
X	X		8	FA-207SF	Sprocket, 11T-80
		X	8	FAC-525	Poly Chain Idler
X			9	FAC-215H	2517 Taper Lock Bushing, 1-15/16
	X	X	10	FAC-230	Sprocket, 16T-80, Taper Lock
	X	X	11	FAC-234H	2012 Taper Lock Bushing, 1-15/16
X			12	FAC-234	Sprocket, 20T-80, Taper Lock
X	X	X	13	FAC-245H	2517 Taper Lock Bushing, 2-3/16
X	X	X	14	FAC283-680L	#80 X157" (158 rollers) chain
X			15	FAC-418M	Sq key 3/8 X 1-1/4"
X	X	X	16	FAC-525	Poly Chain Idler

**680 FRONT AUGER DRIVE
RIGHT HAND DISCHARGE**

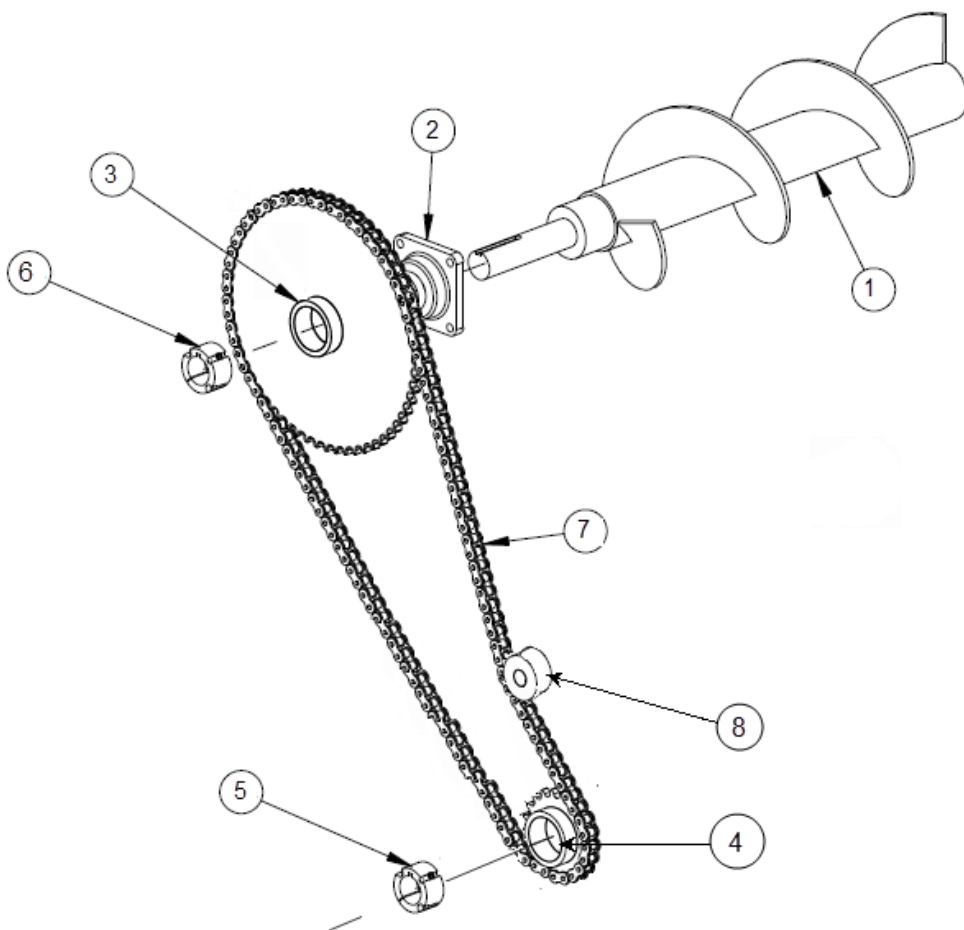

I & II	III & IV	ITEM	PART NUMBER	DESCRIPTION
X	X	1	FAC-818	Auger 680 Specify Left or Right Hand
X	X	2	FAC-108FB-4	Flange Brg, 4 Bolt, 2-3/16
	X	3	FAC-248	Sprocket, 48T-80, Taper Lock
X		3	FAC-2	Sprocket, 60T-80, Taper Lock
	X	4	FAC-230	Sprocket, 16T-80, Taper Lock
X		4	FAC-234	Sprocket, 20T-80, Taper Lock
	X	5	FAC-234H	2012 Taper Lock Bushing, 1-15/16
X		5	FAC-215H	2517 Taper Lock Bushing, 1-15/16
X	X	6	FAC-245H	2517 Taper Lock Bushing, 2-3/16
X	X	7	FAC-283-157R	680 Front Drive #80 Chain X 124 Rollers
X	X	8	FAC-525	Poly Chain Idler
X	X	8	FAC-525B	Bushing for Poly Roller

560 FRONT AUGER DRIVE
LEFT HAND DISCHARGE

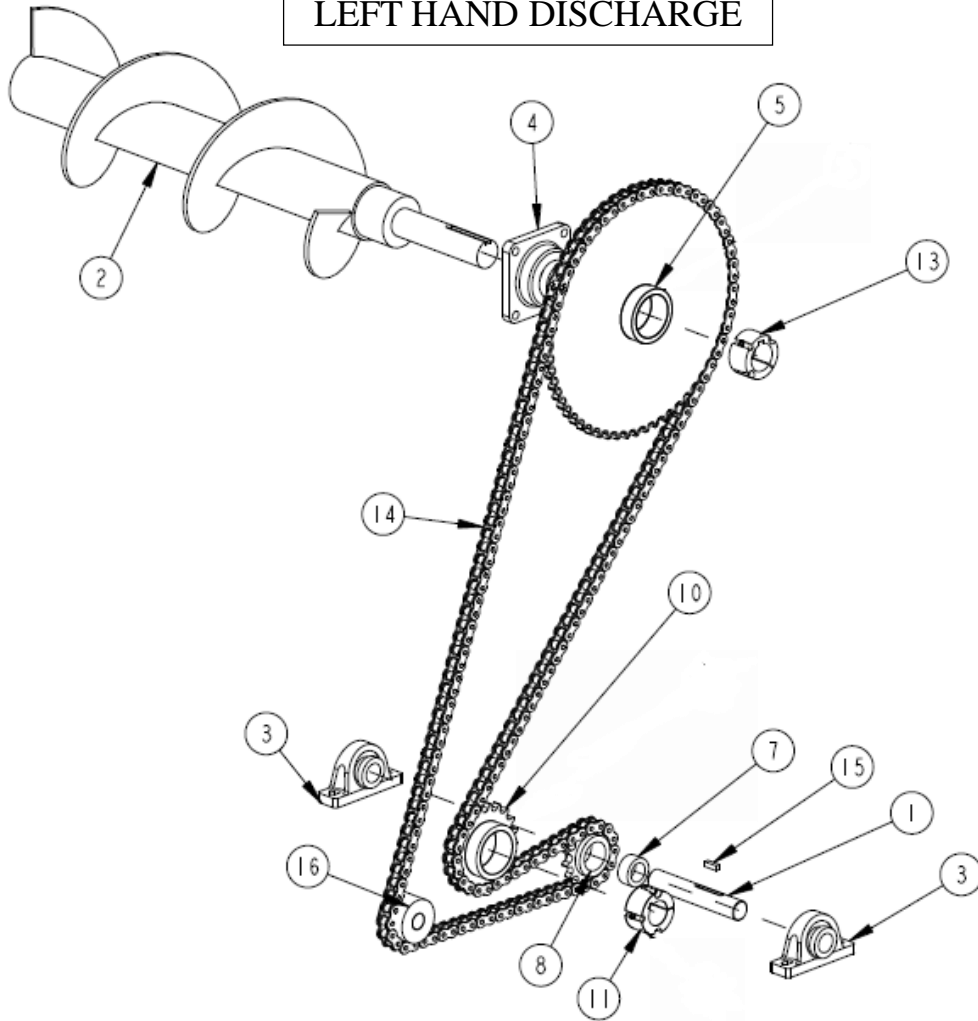

I, II & III	IV	ITEM	PART NUMBER	DESCRIPTION
X		1	FAC-406	Shaft, 1-1/2 X 9
X	X	2	FAC-818	Auger, Specify Left or Right Hand
X		3	FA102PB	Bearing, 1-1/2" Pillow Block
X	X	4	FAC-108FB-4	Flange Brg, 4 Bolt, 2-3/16
X	X	5	FAC-248	Sprocket, 48T-80, Taper Lock
X		7	Not Available	No longer needed with both new style #8
X		8	FA-207SF	Sprocket, 11T-80
	X	8	FAC-525	Poly Chain Idler
X	X	10	FAC-230	Sprocket, 16T-80, Taper Lock
X	X	11	FAC-234H	2012 Taper Lock Bushing, 1-15/16
X	X	13	FAC-245H	2517 Taper Lock Bushing, 2-3/16
X	X	14	FAC283-680L	#80 X157" (158 rollers) chain
		15	FAC-418M	Sq key 3/8 X 1-1/4"
X	X	16	FAC-525	Poly Chain Idler

560 FRONT AUGER DRIVE
RIGHT HAND DISCHARGE

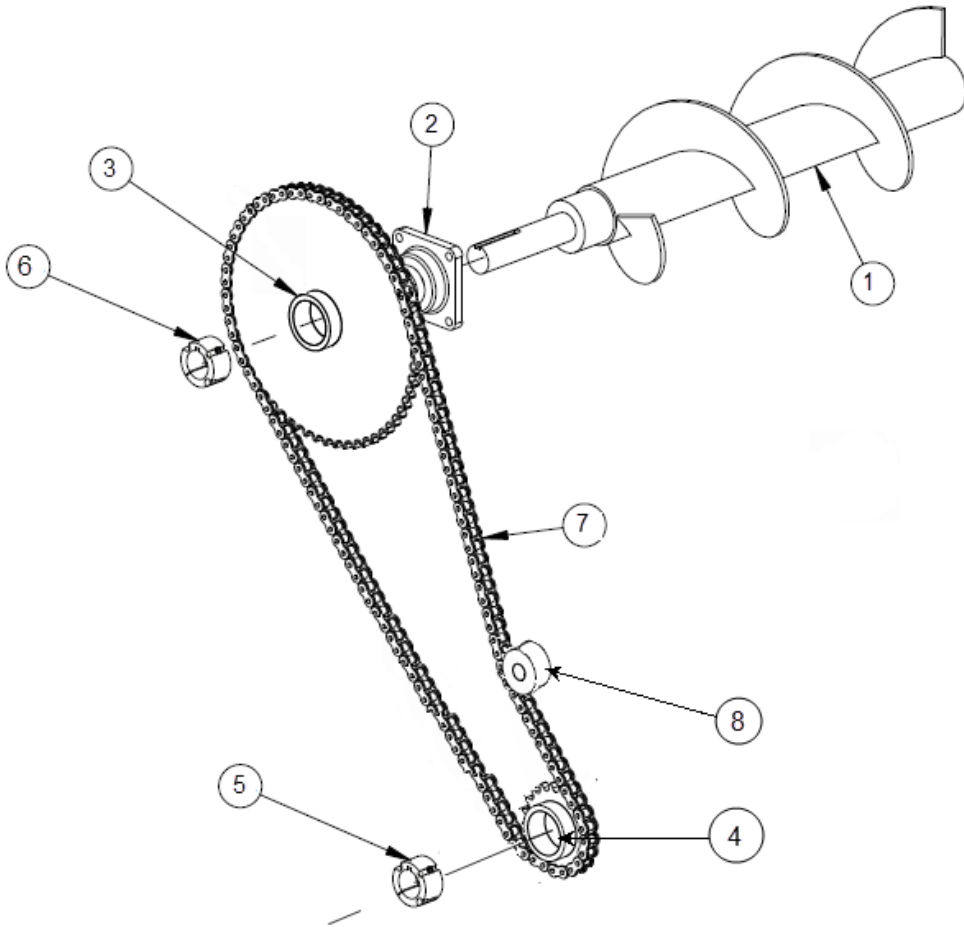

I, II, III, and IV all have these parts

ITEM	PART NUMBER	DESCRIPTION
1	FAC-818	Auger, 560 & 680, Left or Right Hand
2	FAC-108FB-4	Flange Brg, 4 Bolt, 2-3/16
3	FAC-248	Sprocket, 48T-80, Taper Lock*
4	FAC-230	Sprocket, 16T-80, Taper Lock*
5	FAC-234H	2012 Taper Lock Bushing, 1-15/16
6	FAC-245H	2517 Taper Lock Bushing, 2-3/16
7	FAC-283-157R	560 Front Drive #80 Chain X 110 Rollers
7	FAC-283-157R	680 Front Drive #80 Chain X 124 Rollers
8	FAC-525	Poly Chain Idler
8	FAC-525B	Bushing for Poly Roller

680 REAR DRIVE LEFT HAND DISCHARGE

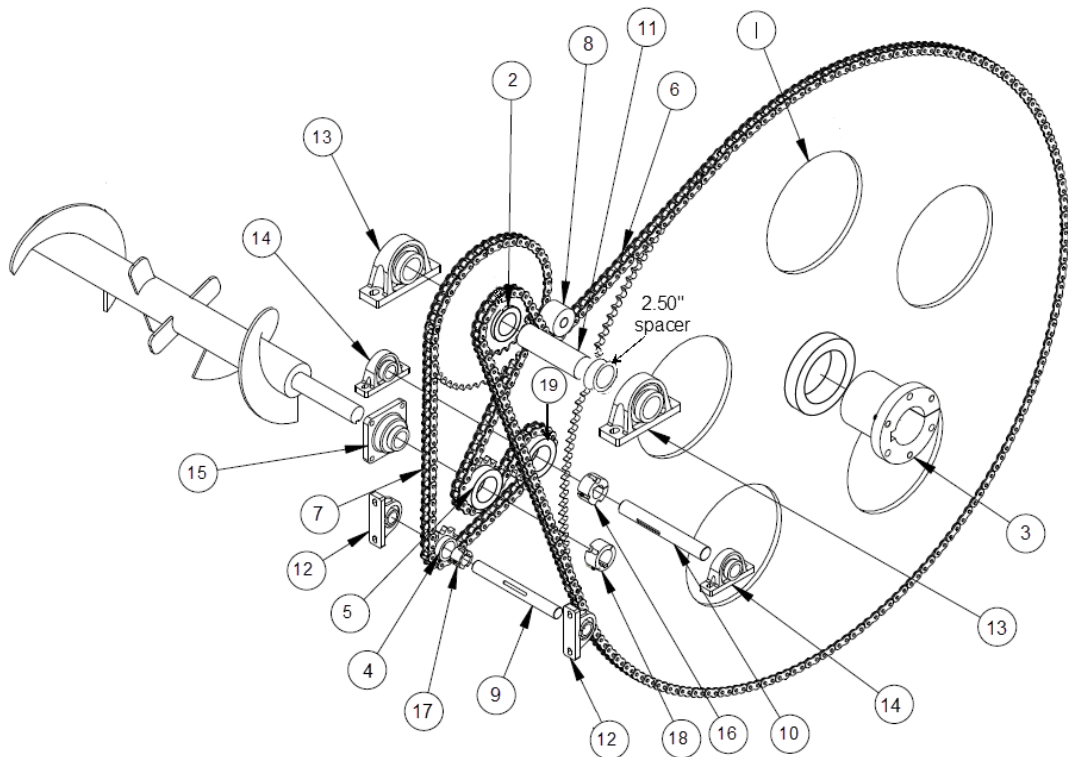

I	II & III	IV	ITEM	P/N	DESCRIPTION
	X	X	1	FAC-174	Sprocket, 174T-120, QD
X			1	FAC-209	Sprocket, 209T-100, QD
	X	X	2	FAC-148	Sprocket Weldment, 48T & 16T
X			2	FAC-216	Sprocket Weldment, 48T & 20T
X	X	X	3	FAC-210	Bushing, 5.00 Dia.
X	X		4	FAC-233	Sprocket, 11T-100, Taper Lock
		X	4	FAC-525	UHMW Roller
X	X	X	5	FAC-235	Sprocket, 16T-100, Taper Lock
	X	X	6	FAC-284-289	120 Chain, Rear Final Drive
X				FAC-282-127	100 Chain, Rear Final Drive (Check the length)
X	X	X	7	FAC-282-134	100 Chain, Rear Initial Drive
X	X	X	8	FAC-347	Poly Idler Roller, Rear
X	X		9	FAC-399	Shaft, 1-1/2 X 9
X	X		10	FAC-405	Shaft, 1-3/4 X 13
X	X		11	FAC-455	Shaft, 560 & 680, 2-15/16 Dia X 13-3/4
X	X	X	12	FAC-102PB	Pillow Block, 1-1/2 W/Bearing
X	X	X	13	FAC-104PB	Pillow Block, 2-15/16 W/Bearing
X	X		14	FA-105PB	Pillow Block Brg, 1-3/4 W/Lock Collar
X	X	X	15	FAC-108FB-4	Flange Brg, 4 Bolt, 2-3/16
X	X		16	FAC-217H	2517 Taper Lock Bushing, 1-3/4
X	X		17	FAC-233H	1615 Taper Lock Bushing, 1-1/2
X	X	X	18	FAC-245H	2517 Taper Lock Bushing, 2-3/16
X	X		19	FAC-235	Sprocket, 16T-100, Taper Lock
		X	19	FAC-547	UHMW ROLLER

680 REAR DRIVE RIGHT HAND DISCHARGE

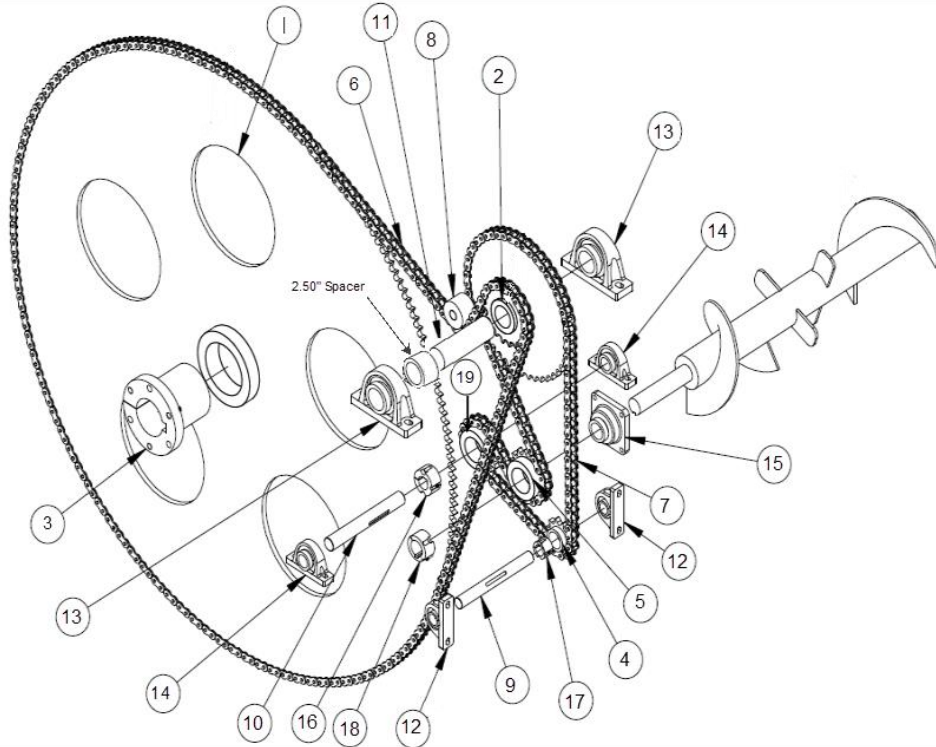

I	II & III	IV	ITEM	P/N	DESCRIPTION
	X	X	1	FAC-174	Sprocket, 174T-120, QD
X			1	FAC-209	Sprocket, 209T-100, QD
	X	X	2	FAC-148	Sprocket Weldment, 48T & 16T
X			2	FAC-216	Sprocket Weldment, 48T & 20T
X	X	X	3	FAC-210	Bushing, 5.00 Dia.
X	X		4	FAC-233	Sprocket, 11T-100, Taper Lock
		X	4	FAC-525	UHMW Roller
X	X	X	5	FAC-235	Sprocket, 16T-100, Taper Lock
	X	X	6	FAC-284-289	120 Chain, Rear Final Drive
X				FAC-282-127	100 Chain, Rear Final Drive (Check the length)
X	X	X	7	FAC-282-134	100 Chain, Rear Initial Drive
X	X	X	8	FAC-347	Poly Idler Roller, Rear
X	X		9	FAC-399	Shaft, 1-1/2 X 9
X	X		10	FAC-405	Shaft, 1-3/4 X 13
X	X		11	FAC-455	Shaft, 560 & 680, 2-15/16 Dia X 13-3/4
X	X	X	12	FAC-102PB	Pillow Block, 1-1/2 W/Bearing
X	X	X	13	FAC-104PB	Pillow Block, 2-15/16 W/Bearing
X	X		14	FA-105PB	Pillow Block Brg, 1-3/4 W/Lock Collar
X	X	X	15	FAC-108FB-4	Flange Brg, 4 Bolt, 2-3/16
X	X		16	FAC-217H	2517 Taper Lock Bushing, 1-3/4
X	X		17	FAC-233H	1615 Taper Lock Bushing, 1-1/2
X	X	X	18	FAC-245H	2517 Taper Lock Bushing, 2-3/16
X	X		19	FAC-235	Sprocket, 16T-100, Taper Lock
		X	19	FAC-547	UHMW ROLLER

560 REAR DRIVE LEFT HAND DISCHARGE

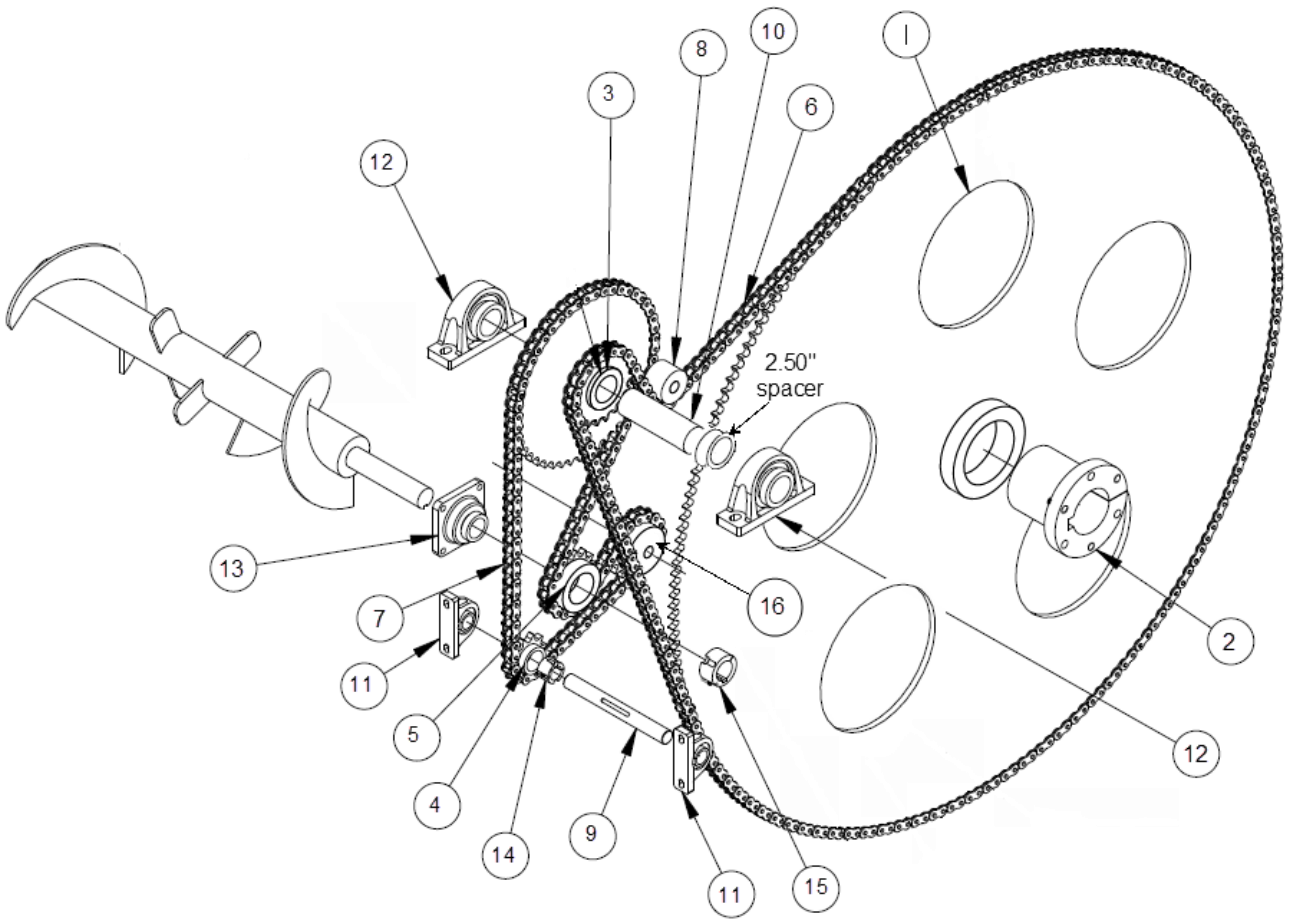

I, II & III	IV	ITEM	P/N	DESCRIPTION
X	X	1	FAC-209	Sprocket, 209T-100,QD
X	X	2	FAC-210	Bushing, 5.00 Dia.
X	X	3	FAC-216	Sprocket Weldment, 48T & 20T
X		4	FAC-233	Sprocket, 11T-100, Taper Lock
	X	4	FAC-525	UHMW roller
X	X	5	FAC-235	Sprocket, 16T-100, Taper Lock
X	X	6	FAC282-289	100 Chain, Rear Final Drive
X	X	7	FAC281-127	100 Chain, Rear Initial Drive
X	X	8	FAC-347	UHMW roller
X		9	FAC-399	Shaft, 1-1/2 X 9
X	X	10	FAC-455	Shaft, 2-15/16 Dia X 13-3/4
X		11	FA-102PB	Pillow Block, 1-1/2 W/Bearing
X	X	12	FA-104PB	Pillow Block, 2-15/16 W/Bearing
X	X	13	FAC-108FB-4	Flange Brg, 4 Bolt, 2-3/16
X		14	FAC-233H	1615 Taper Lock Bushing, 1-1/2
X	X	15	FAC-245H	2517 Taper Lock Bushing, 2-3/16
X	X	16	FAC-547	UHMW roller

560 REAR DRIVE RIGHT HAND DISCHARGE

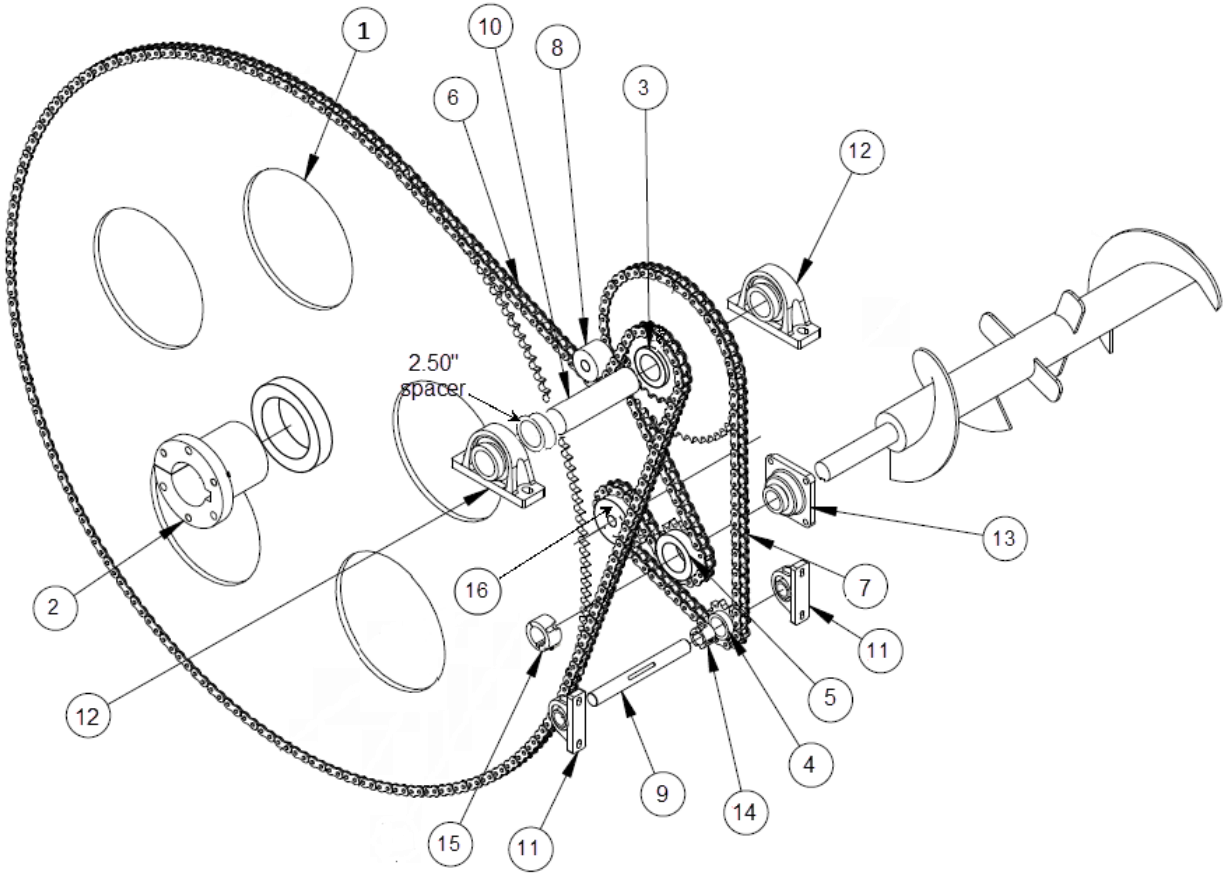

I, II & III	IV	ITEM	P/N	DESCRIPTION
X	X	1	FAC-209	Sprocket, 209T-100,QD
X	X	2	FAC-210	Bushing, 5.00 Dia.
X	X	3	FAC-216	Sprocket Weldment, 48T & 20T
X		4	FAC-233	Sprocket, 11T-100, Taper Lock
	X	4	FAC-525	UHMW roller
X	X	5	FAC-235	Sprocket, 16T-100, Taper Lock
X	X	6	FAC282-289	100 Chain, Rear Final Drive
X	X	7	FAC281-127	100 Chain, Rear Initial Drive
X	X	8	FAC-347	UHMW roller
X		9	FAC-399	Shaft, 1-1/2 X 9
X	X	10	FAC-455	Shaft, 2-15/16 Dia X 13-3/4
X		11	FA-102PB	Pillow Block, 1-1/2 W/Bearing
X	X	12	FA-104PB	Pillow Block, 2-15/16 W/Bearing
X	X	13	FAC-108FB-4	Flange Brg, 4 Bolt, 2-3/16
X		14	FAC-233H	1615 Taper Lock Bushing, 1-1/2
X	X	15	FAC-245H	2517 Taper Lock Bushing, 2-3/16
X	X	16	FAC-547	UHMW roller

ASSY, 560 & 680 ELEVATOR
Right and Left Hand Discharge

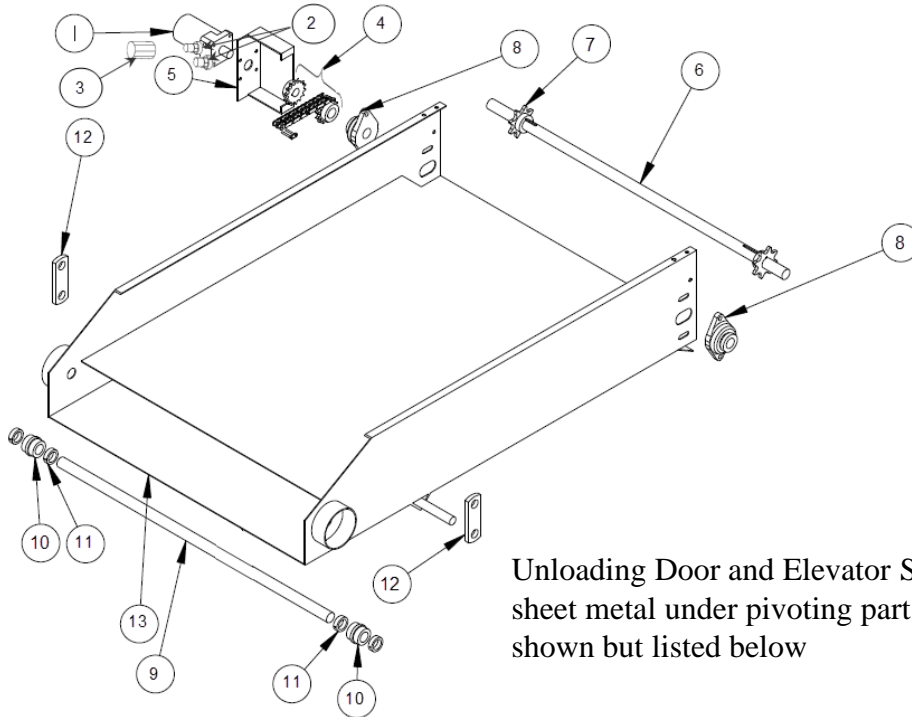

Unloading Door and Elevator Saddle (round sheet metal under pivoting part of elevator) not shown but listed below

ITEM	PART NUMBER	DESCRIPTION
1	FAC-509	Hydraulic Motor
	FAC60540-000	Seal Kit Char Lynn Motor
	FAC509S	Seal Kit Dynamic Fluid Hydraulic Motor
	FAC22000-002	End Plate for Dynamic Fluid Hydraulic Motor
2	FAC509A	7/8-14M x 1/2" (Hydraulic Motor Fitting)
3	FAC568	Check Valve
4	FAC529A	Hydraulic Drive Kit (Sprockets, Chain, and Link)
5	FAC-518	Mount, Hydraulic Motor
6	FAC-511	Shaft, 1-1/4 X 46
7	FAC-555	Conveyor Sprocket, 755 X 1-1/4 Bore
8	FAC-101FB-2	Flange Bearing, 2-Bolt, 1-1/4 Bore W/Locking Collar
9	FAC-512	Driven Shaft, 1-1/4 X 42
10	FAC-513	Elevator Idler Roll
11	FAC-514	Set Collar, 1-1/4
12	FAC-520	Connector Link, Cylinder
13	FAC-500-3	Elevator Weldment, 3 Ft. Includes Rollers and Shaft
	FAC-500-4	Elevator Weldment, 4 Ft. Includes Rollers and Shaft
	FAC-500-5	Elevator Weldment, 5 Ft. Includes Rollers and Shaft
	FAC-517-3	3' Elevator Complete, Less Motor and Mount
	FAC-517-4	4' Elevator Complete, Less Motor and Mount
	FAC-517-5	5' Elevator Complete, Less Motor and Mount
	FAC350S	Unloading Door
	FAC536ES	Elevator Saddle

560 & 680 ELEVATOR CHAIN AND OPTIONS
LEFT AND RIGHT HAND DISCHARGE

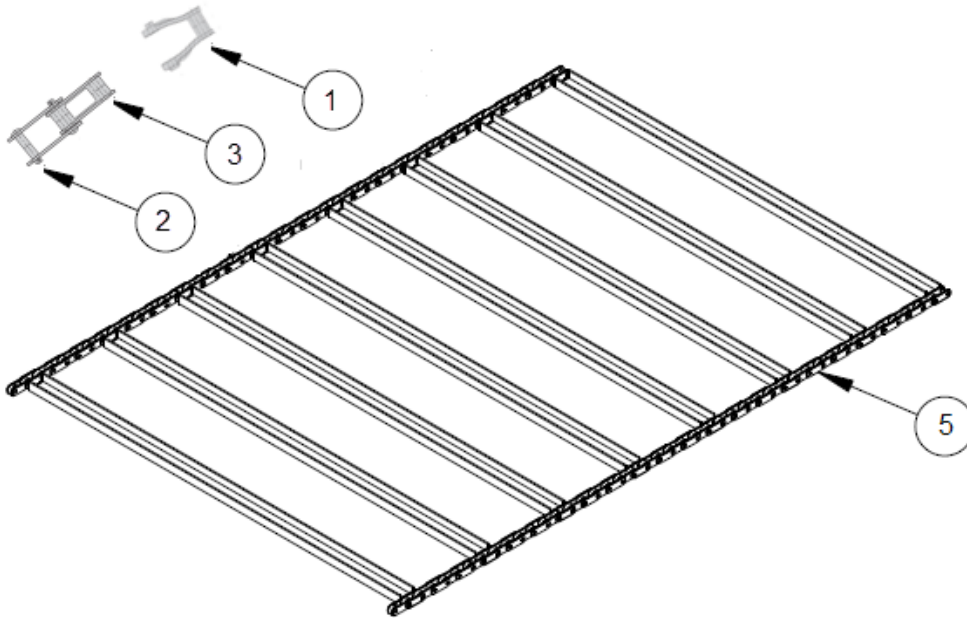

ITEM	PART NUMBER	DESCRIPTION
1	FAC515OS	Offset Connector (1/2 Link)
2	FAC515C	Connector
3	FAC510L	Link, Cast
5	FAC-516-3	Elevator Chain, 3 Ft.
	FAC-516-4	Elevator Chain, 4 Ft.
	FAC-516-5	Elevator Chain, 5 Ft.
	FAC748	Magnet Assembly With Mounting Brackets
	SFAC748	Magnet Only (2 needed)
	FAC520	Elevator Hood With Mounting Brackets

**ASSY, 560 & 680 SPIRAL
LEFT AND RIGHT HAND DISCHARGE**

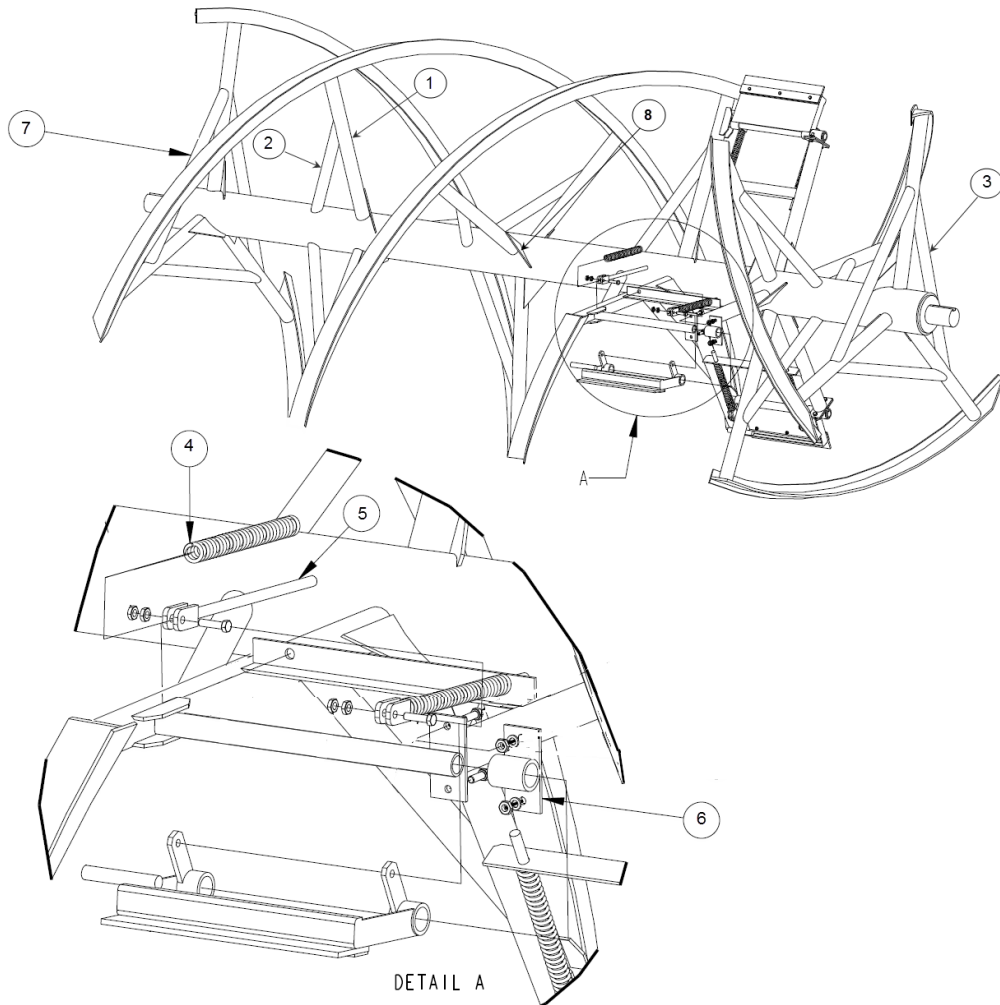

ITEM	PART NUMBER	DESCRIPTION
1	FAC-844	680 SPIRAL SPOKE, 3"
1	FAC-843	560 SPIRAL SPOKE 2 1/2"
2	FA-817	560 SPOKE BRACE PIPE 1 1/4" x 27"
2	FAC-844BP	680 SPOKE BRACE PIPE 2"
3	FAC-819KP	680 SPIRAL SUPPORT, 2"
3	FAC-820	560 SPIRAL SUPPORT. 1 1/4"
4	FA-335C	COMPRESSION SPRING
5	FA-335SR	KICKER SPRING ROD
6	FAC-337	SUPPORT, 560/680 KICKER
7	FAC-846	560 SPIRAL
7	FAC-848	680 SPIRAL
8	B1FA-815	SPIRAL GUSSET

**ASSY, 560 & 680 KICKER W/BELT
LEFT AND RIGHT HAND DISCHARGE**

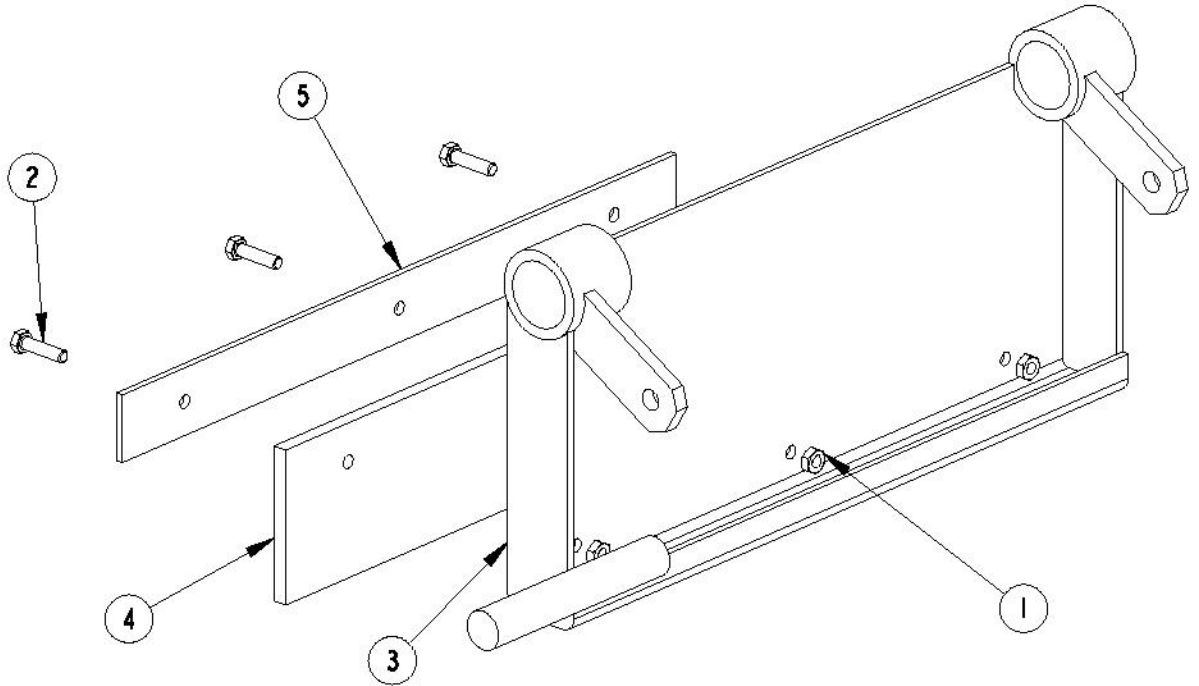

Early style kicker shown, Later ones are visually different but fit the same

ITEM	PART NUMBER	DESCRIPTION
1		5/16-18NC Hex Nut
2		Hex HD Bolt, 5/16-18NC X 1.00
3	FAC-336	560/680 Kicker W/Belt
4	FAC-336B	Kicker Belt, 680
5	KICKER-STRAP_680	Kicker Belt Retainer, 680

**BACK SPIRAL AND SWEEP 560 & 680
RIGHT AND LEFT HAND DISCHARGE**

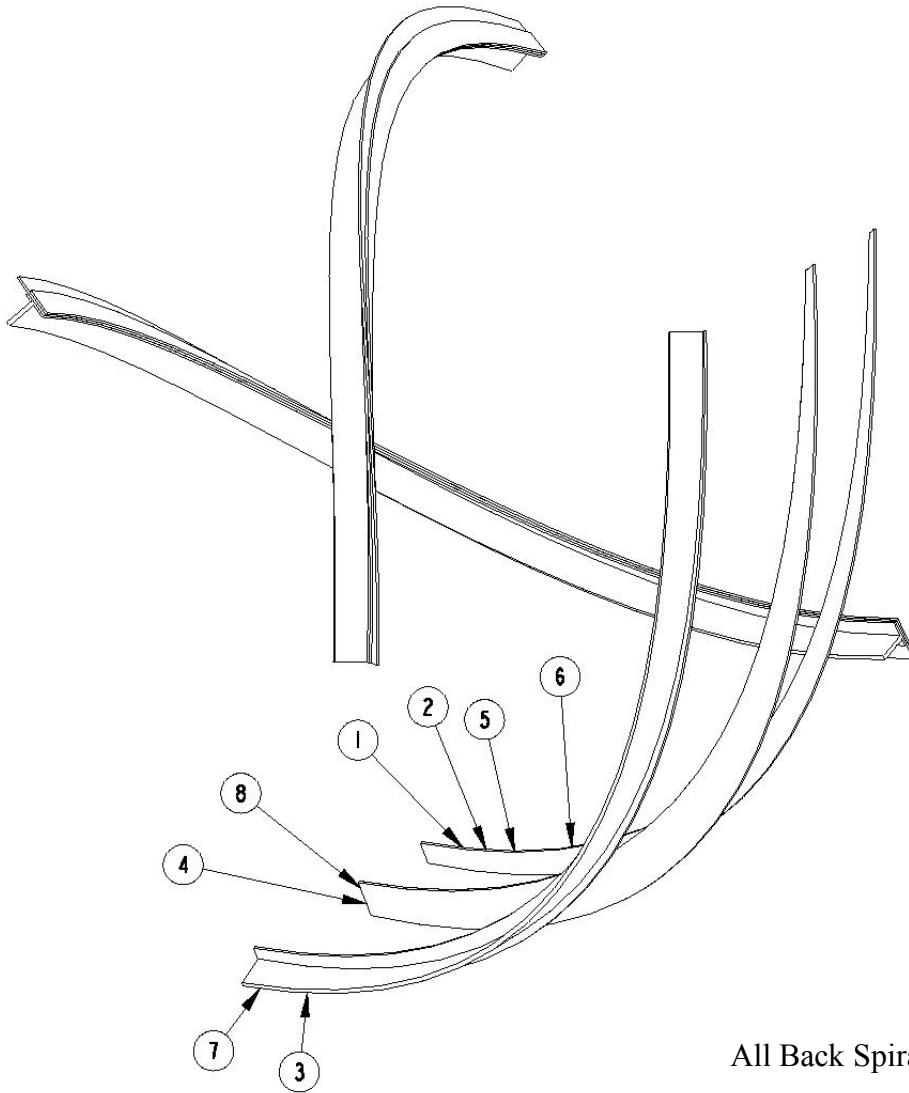

All Back Spirals are 20'

ITEM	PART NUMBER	DESCRIPTION
1	FAC-704BF	Back Spiral Face Material, 560, Left or Right Hand
2	FAC-704BF-H	Back Spiral Face Material W/Holes, 560, Left and Right Hand
3	FAC-704BS	Back Spiral Support Material, 560, Left and Right Hand
4	FAC-705B	Sweep Clean Belt, 680 & 560
5	FAC-705BF	Back Spiral Face Material, 680, Left or Right Hand
6	FAC-705BF-H	Back Spiral Face Material W/Holes, 680, Left or Right Hand
7	FAC-705BS	Back Spiral Support Material, 680, Left or Right Hand
8	FAC-705B	Sweep Clean Belt, 680 & 560

**FRONT SPIRAL AND SWEEP 560 & 680
RIGHT AND LEFT HAND DISCHARGE**

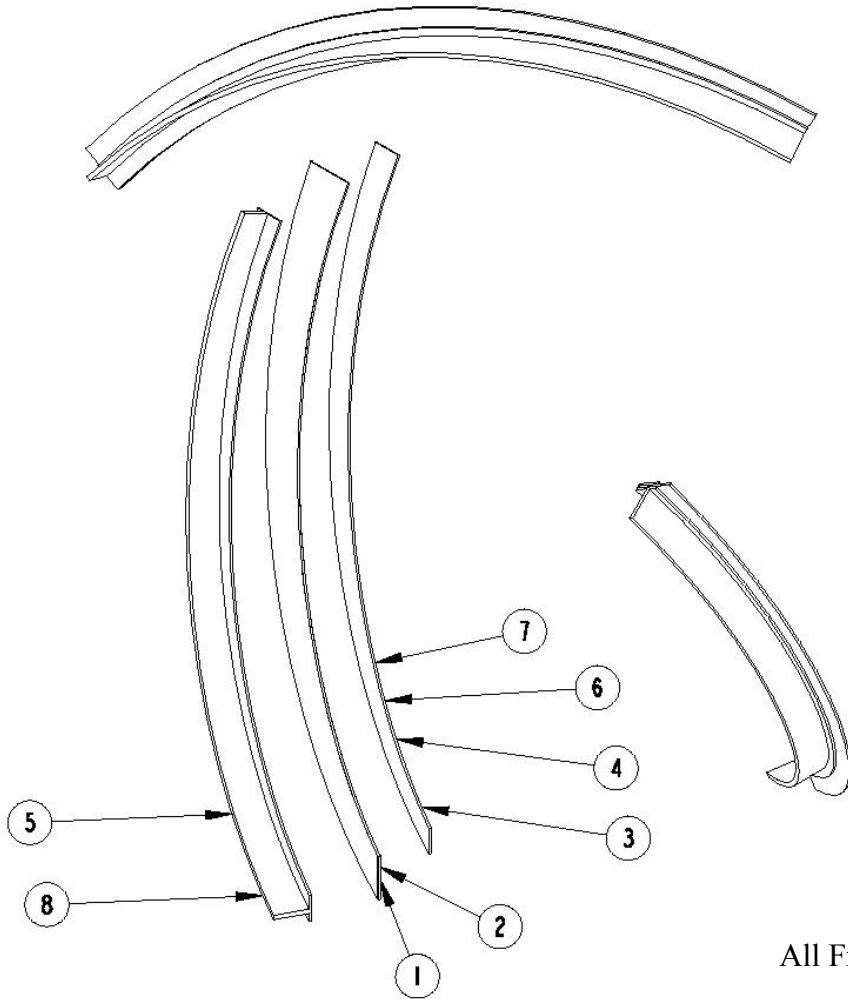

All Front Spirals are 7'

ITEM	PART NUMBER	DESCRIPTION
1	FAC-705B	Sweep Clean Belt, 680 & 560
2	FAC-705B	Sweep Clean Belt, 680 & 560
3	FAC-704FF	Front Spiral Face Material, 560, Left or Right Hand
4	FAC-704FF-H	Front Spiral Face Material W/Holes, 560, Left or Right Hand
5	FAC-704FS	Front Spiral Support Material, 560, Left or Right Hand
6	FAC-705FF	Front Spiral Face Material, 680, Left or Right Hand
7	FAC-705FF-H	Front Spiral Face Material W/Holes, 680, Left or Right Hand
8	FAC-705FS	Front Spiral Support Material, 680, Left or Right Hand

**SPINDLE AND HUB 560 & 680
RIGHT AND LEFT AND DISCHARGE**

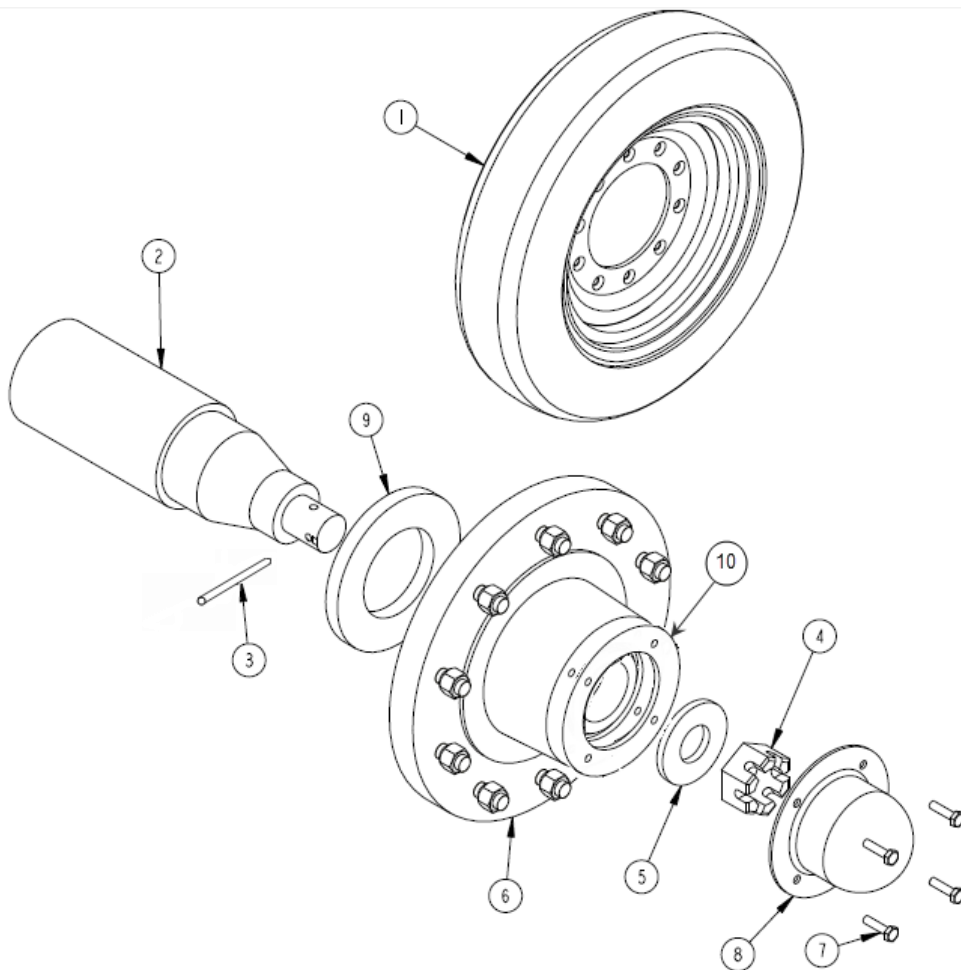

ITEM	PART NUMBER	DESCRIPTION
1	FA-622WH	Wheel, 13.5 X 22.5 X 10
2	FAC-630	680 & 560 Spindle
3	FAC-630RP	Roll Pin
4	FAC-630SN	Spindle Nut
5	FAC-630W	Spindle Washer, 680 & 560
6	FAC-631CA	Assy, 560 & 680 Hub W/Bearings
7	FAC-631CB	Bolt, Hub Cap
8	FAC-631HC	Hub Cap
9	FAC-631S	Bearing Seal
10	FAC-631GAS	Gasket

SPINDLE AND HUB

HUB W/BEARINGS 560 & 680
RIGHT AND LEFT HAND DISCHARGE

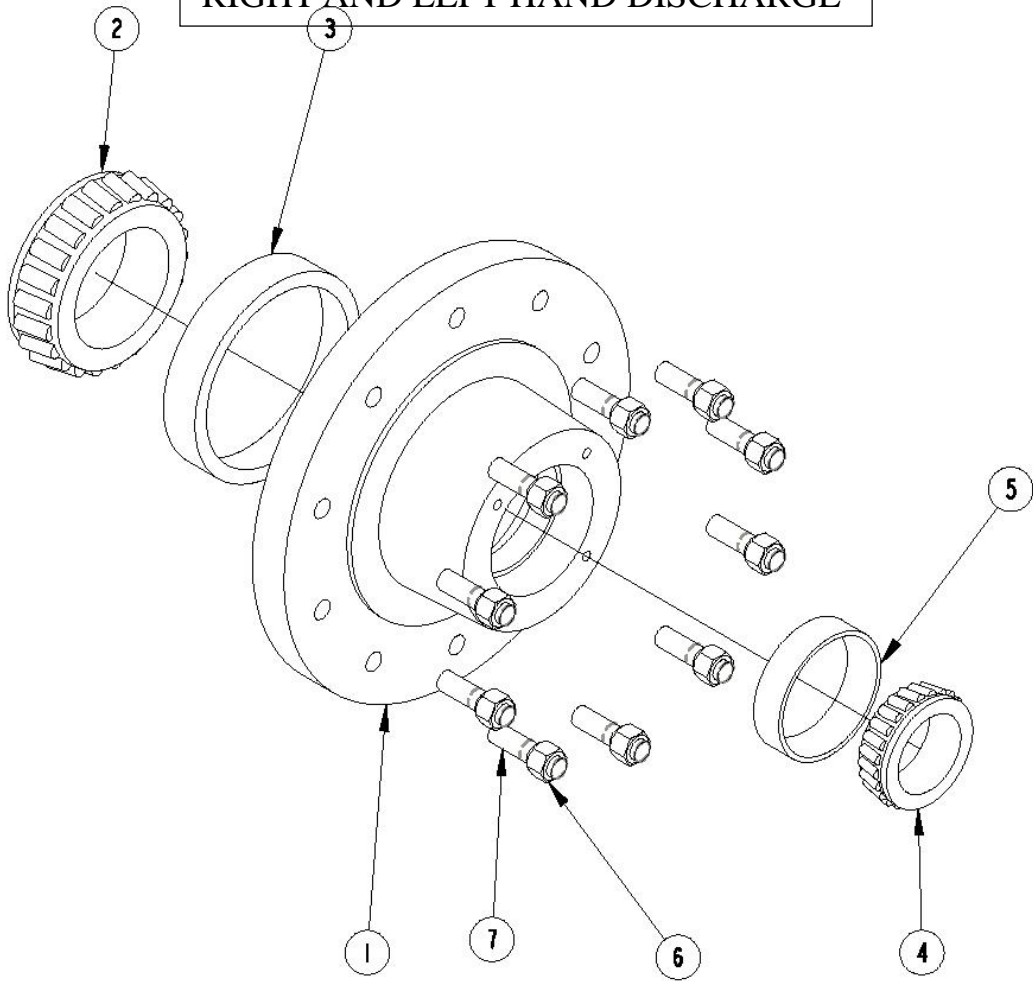

ITEM	PART NUMBER	DESCRIPTION
1	FAC-631	680 & 560 Hub W/Races
2	FAC-631IB	Bearing, Inside
3	FAC-631IR	Bearing Race, Inside
4	FAC-631OB	Bearing, Outer
5	FAC-631OR	Bearing Race, Outer
6	FAC-631WN	Wheel Nut, 680 & 560
7	FAC-631WS	Stud Bolt

HUB W/BEARINGS

EXTERNAL PARTS IN REAR, 560 & 680
RIGHT AND LEFT HAND DISCHARGE

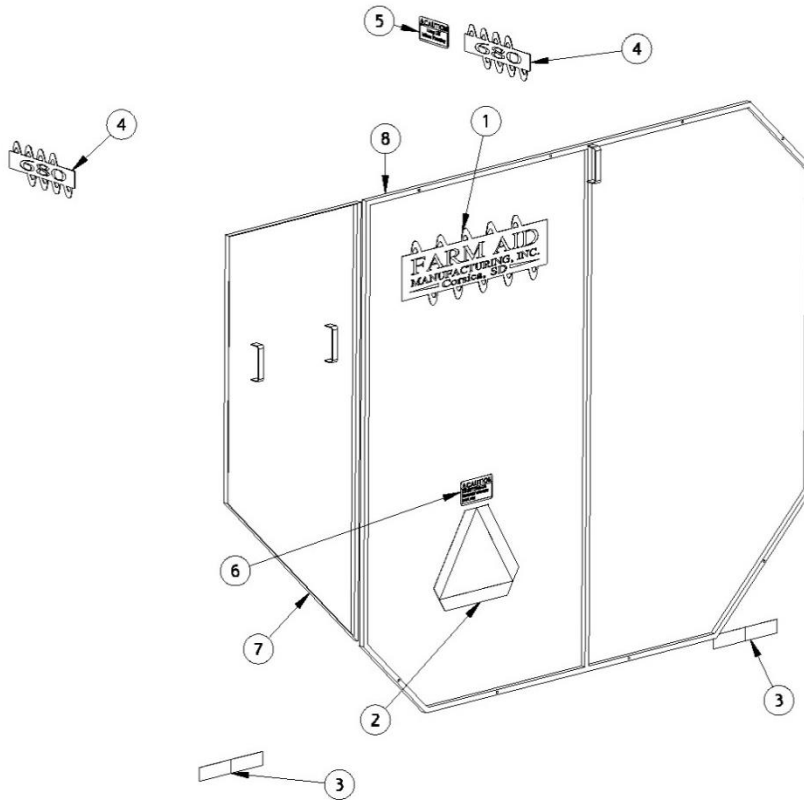

ITEM	PART NUMBER	DESCRIPTION
1	FA-356	Decal, Farm Aid Equipment, Inc. Mfg
2	FA-357	Decal, Slow Travel
3	FA-359	Decal, Reflective
4	FA-356	Decal, 560 & 680 (Specify Model)
5	FA-358A	Decal, "Caution: Keep Off When Running"
6	FA-358C	Decal, "Caution: Do Not Operate Without Guards in Place"
7	FAC-008	LH Rear Shield, Model 560 & 680, Left or Right Hand
8	FAC-006B	RH Rear Shield, Model 560 & 680, Left or Right Hand
	FA760L	Replacement Lamp Assy
	FA760Amber	Replacement Amber Lens
	FA760Red	Replacement Red Lens
	FA760Black	Replacement Black Lens
	FA760B	Lamp Mounting Bracket

This page was left blank intentionally

**POLY LINERS, 560 & 680
LEFT HAND DISCHARGE**

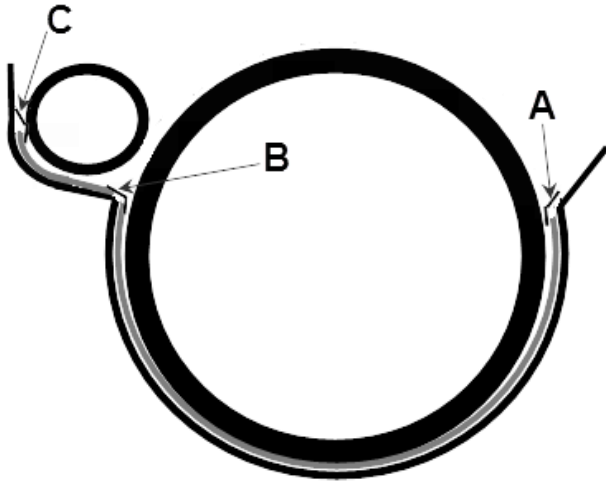

STRIP SIZE CHART			
MODEL	A	B	C
front	72.13	71.5*	72.13
middle	71.75	72**	71.75
back	35.5	35	35.5

•use angle FA 7420

•** uses FA 7410

	P / N	DESCRIPTION
	FAC736KL	POLY FLOOR LINER KIT, MODEL 680
	FAC736APL	POLY AUGER LINER KIT, MODEL 680
	FAC736-1L	FRONT POLY SHEET, MODEL 680
	FAC736-2L	2nd POLY SHEET, MODEL 680
	FAC736-3L	3rd POLY SHEET, MODEL 680
	FAC736-4L	BACK POLY SHEET, MODEL 680
	FAC738KL	POLY FLOOR LINER KIT, MODEL 560
	FAC738APL	POLY AUGER LINER KIT, MODEL 560
	FAC738-1L	FRONT POLY SHEET, MODEL 560
	FAC738-2L	2nd POLY SHEET, MODEL 560
	FAC738-3L	3rd POLY SHEET, MODEL 560
	FAC738-4L	BACK POLY SHEET, MODEL 560
A/B/C	FA 7210	2" STRIP, (SOLD BY FOOT) PLEASE CHART ABOVE
B	FA 7410	2" ANGLE, (SOLD BY FOOT) PLEASE CHART ABOVE
	FA757	CARRIAGE BOLT (560-Qt 39; 680-Qt 39 Auger 23)
	FA756B	ELEVATOR BOLT (560-Qt 57; 680-Qt 64 Auger 7)
	FA755	5/16" TORX SCREW (560-Qt 31; 680-Qt 31 Auger 30)

**POLY LINERS, 560 & 680
RIGHT HAND DISCHARGE**

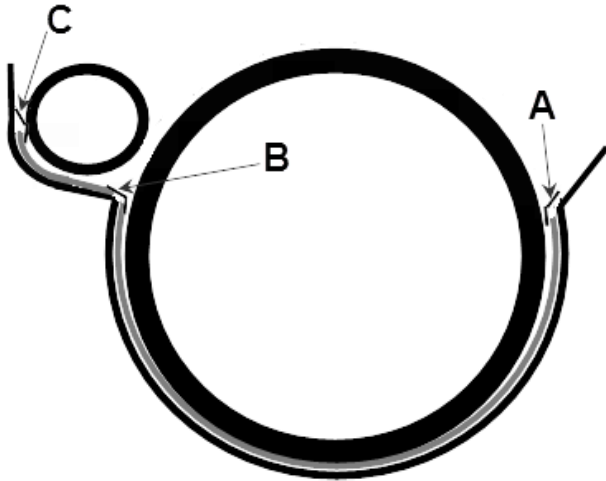

STRIP SIZE CHART			
MODEL	A	B	C
front	72.13	71.5*	72.13
middle	71.75	72**	71.75
back	35.5	35	35.5

•use angle FA 7420

•** uses FA 7410

	P / N	DESCRIPTION
	FAC736KR	POLY FLOOR LINER KIT, MODEL 680
	FAC736APR	POLY AUGER LINER KIT, MODEL 680
	FAC736-1R	FRONT POLY SHEET, MODEL 680
	FAC736-2R	2nd POLY SHEET, MODEL 680
	FAC736-3R	3rd POLY SHEET, MODEL 680
	FAC736-4R	BACK POLY SHEET, MODEL 680
	FAC738KR	POLY FLOOR LINER KIT, MODEL 560
	FAC738APR	POLY AUGER LINER KIT, MODEL 560
	FAC738-1R	FRONT POLY SHEET, MODEL 560
	FAC738-2R	2nd POLY SHEET, MODEL 560
	FAC738-3R	3rd POLY SHEET, MODEL 560
	FAC738-4R	BACK POLY SHEET, MODEL 560
A/B/C	FA 7210	2" STRIP, (SOLD BY FOOT) PLEASE CHART ABOVE
B	FA 7410	2" ANGLE, (SOLD BY FOOT) PLEASE CHART ABOVE
	FA757	CARRIAGE BOLT (560-Qt 39; 680-Qt 39 Auger 23)
	FA756B	ELEVATOR BOLT (560-Qt 57; 680-Qt 64 Auger 7)
	FA755	5/16" TORX SCREW (560-Qt 31; 680-Qt 31 Auger 30)